

TEMPERATURE MEASUREMENT FOR GLASS

Non-contact temperature sensors for improved process monitoring and greater efficiency in glass production processes



TRUSTED SOLUTIONS

Advanced Energy delivers trusted temperature measurement solutions for glass production processes.

With a 60-year history of creating efficiencies through light-based measurement, Advanced Energy delivers trusted temperature measurement solutions for glass manufacturers. Accurate and precise temperature monitoring is critical for efficient and cost effective melting, glass viscosity control, heat zone adjustment, annealing, and stress reduction.

Temperature measurement is also directly related to glass quality as well as prolonging the life of critical assets such as refractory walls. System solutions involving non-contact thermal imaging combined with pyrometry can help increase production efficiency and reduce waste.

To realize these efficiency improvements, operators need to implement temperature measurement solutions to understand how their equipment is performing and detect developing failures. Our temperature solutions provide highly

accurate data to help professionals realize condition-based maintenance with continuous and remote monitoring.

Our unrivaled passion for excellence is why we have become the one of the world's most trusted sensing solution providers. Beyond providing precision engineered instruments, our customers turn to us knowing our commitment to their success comes first. With expert application understanding and a growing portfolio of products, Advanced Energy can combine several technologies together into novel solutions for the most complex environments.

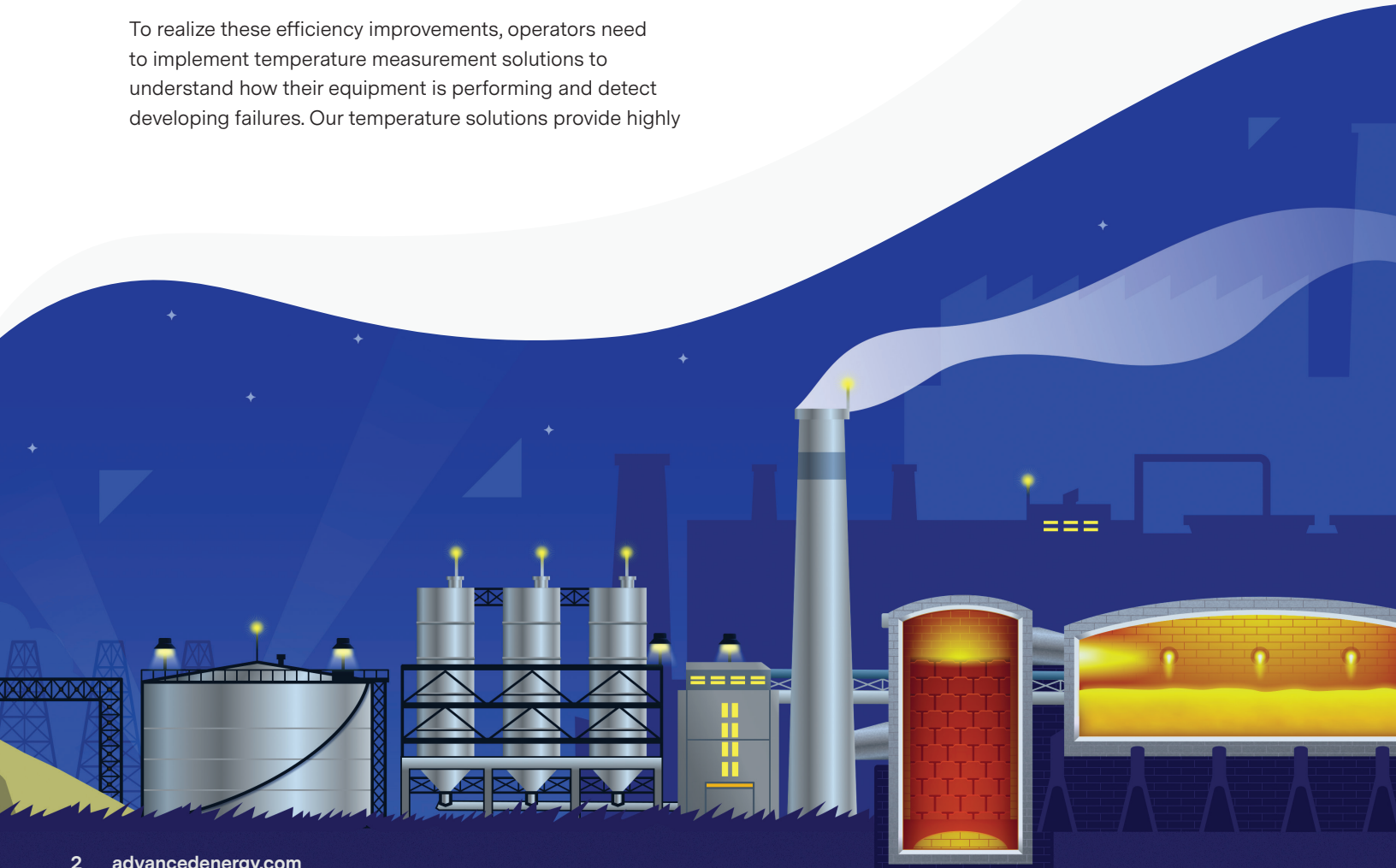

COMMON APPLICATIONS



Flat glass and solar glass

e.g. for the architectural and automotive sectors



Thin and thinnest sheet glass

e.g. for smart phones, tablets, flat panel displays, solar panels and safety glass



Container and utility glassware

e.g. for bottles, containers and drinking glasses



Technical glass

e.g. lamps, lightbulbs, energy saving lamps and tubes, optical glass fiber, glass wool, and optical instruments



Process optimization through non-contact temperature measurements

Temperature measurement is key to the monitoring and optimization of energy-intensive glass production processes.

Careful temperature monitoring during glass production is the only way to ensure that product quality will meet the stringent marketplace requirements.

Temperatures during the various production stages are mostly measured without contact, e.g. in the glass melting tank, in the working tank, in the feeder, or in the gob.

The principal advantages of non-contact measurements are:

- Easy handling
- High flexibility
- Fast response
- Prolonged service life
- Increased throughput rates
- No contamination of the molten glass

Digital measuring equipment with compact electronic components guarantees fast and precise temperature measurements with excellent repeatability.

60 + years of experience

Advanced Energy offers more than 60 years of experience in non-contact measuring technologies with two product types:

PYROMETRY

THERMAL IMAGING

Choose from a wide range of non-contact thermometers whose ruggedness and precision are tailored to the specific needs of the glass industry.

Whether it be for flat glass, solar glass, container glassware, utility glassware, or technical glass, all of our products deliver fast and accurate temperature readings. Customers receive optimum solutions to their specific challenges through intensive consultation with our sales and application engineers.

Emissivity of Glass in the Infrared Spectrum

Many important optical properties of flat glass **transmission** (τ), **reflection** (ρ) and **emissivity** (ϵ) (or **absorption** (α)) affect the performance in many common applications. The high energy UV portion of the solar spectrum (wavelength less than 400 nm) can be damaging to many materials including human skin. Since the transmission of glass is relatively low in this region, thick glass can be an effective UV block. Visual light (400 to 750 nm) easily passes through glass since the transmission is very high in this region. For the longer wavelength near infrared radiation (NIR) (750 to 2500 nm), which is the heat generating portion of the solar spectrum, a large fraction also passes through glass as the transmission is relatively high. Coatings can be applied to the glass surfaces prior to annealing to raise the reflectivity (ρ) of glass in the NIR region. This 'low-E' glass can help to reflect, and retain heat generated inside a building during cool conditions, and reflect heat from the sun during warm days.

During glass manufacturing, accurate control of the process temperatures is critical to ensuring a quality product. For non-contact infrared temperature measurement systems, fully understanding the importance of the parameters is needed to select the correct instruments.

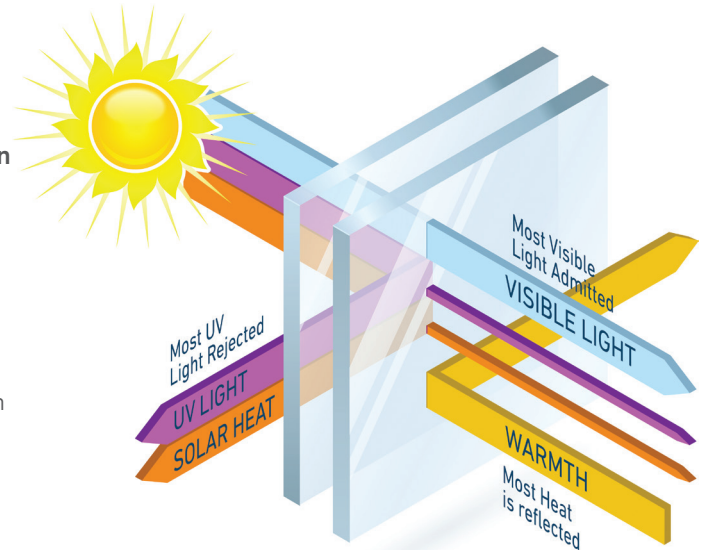

A pyrometer or thermal imager with a detector that is sensitive at 1 μm , can be used to look through thin glass and measure wall temperatures as the glass emissivity is small, and transmission is large. If there is sufficient glass thickness, such as in the melt tank, then the bulk glass temperature can be measured. For thinner glass, selecting detectors that are sensitive in the 5 to 8 μm range will ensure very high emissivity, and accurate measurements on the surface of the plate. A 3.9 μm detector can be used to measure the temperature a few centimeters down into the glass.

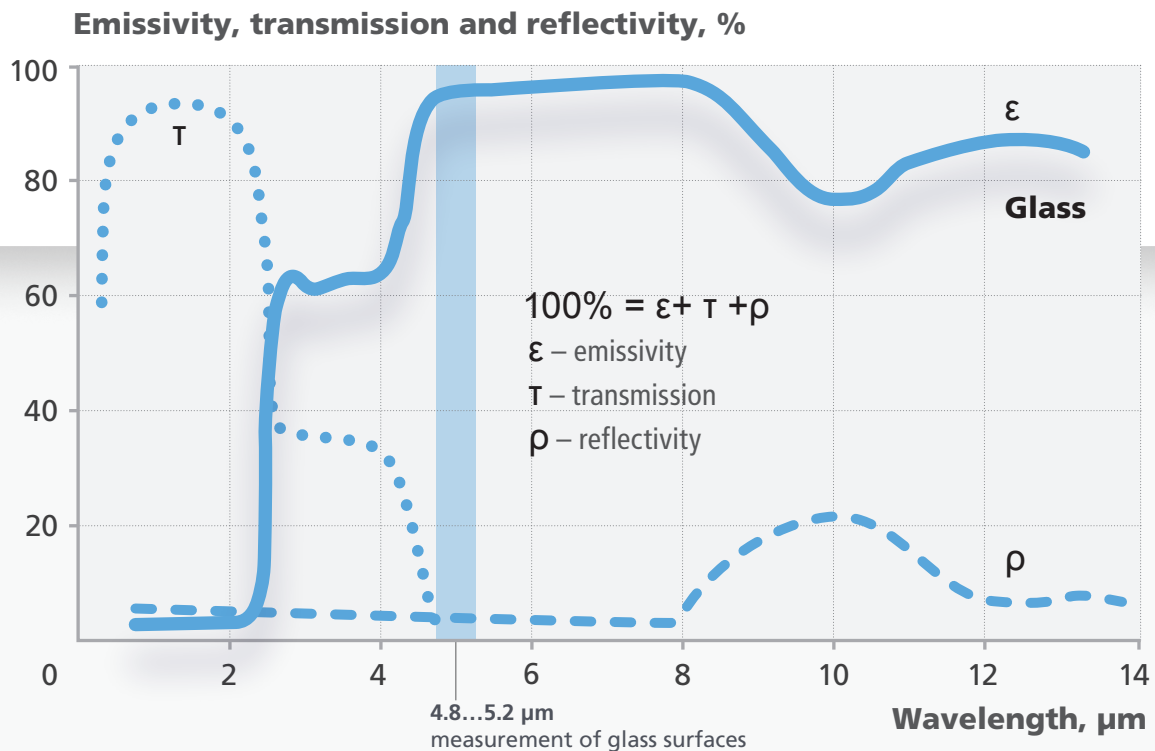

Glass Melting

Regenerator

Regenerators play an important role in the glass melting process. They enable higher operating temperatures and more efficient melting in the melting tank.

Protecting the expensive regenerator crown refractory using temperature measurement enables operators to maintain efficient and stable operation of the melting tank. Typical thermocouples deteriorate over time and can be unreliable. Infrared pyrometers measure temperature without contact and remain outside high temperature zones, providing long-term stability and reliability.

Melting Tank

The melting tank is where the process starts with sand, limestone, soda ash, and cullet feed into a furnace for melting.

Because of the high temperatures and corrosive molten glass required for this process, protecting the expensive bottom refractory from excessive temperature is essential for longevity.

Monitoring the temperatures of the bridgewall and port arch can also provide information on the furnace condition.

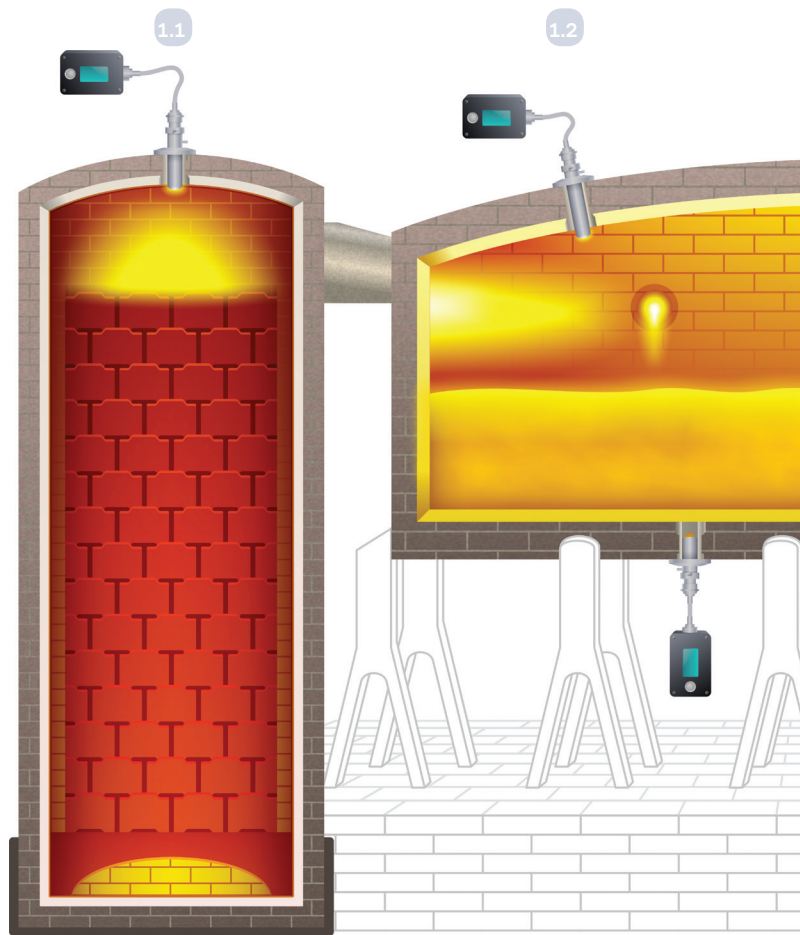

Regenerator

PROCESS STAGE

01 Checking the roof temperature

Challenges

Ensure the stability of the roof through temperature measurements in this area.

Wear-resistant temperature measuring systems delivering continuous, reliable data.

Advanced Energy's solution

Rugged fixed-installation instrument that has a closed ceramic or inconel tube, or with a handheld precision instrument.

Customer benefits

Avoiding glass runout due to refractory failure and high costs resulting from loss of production.

Roof-mounting

SOLUTIONS: Series 50-LO plus pyrometers with closed ceramic or inconel tube

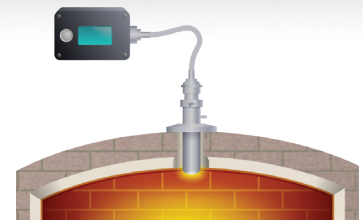

Fixed installation pyrometer

SOLUTIONS: Series 50-LO/GL pyrometers with open-ended ceramic or inconel tube

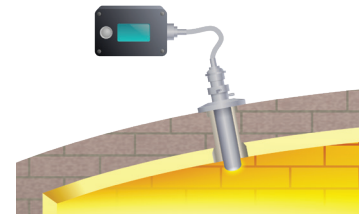

Mobile inspection

SOLUTIONS: Series 8 pro pyrometers



SOLUTIONS FOR GLASS APPLICATIONS

PROCESS STAGE

03 Monitoring the tank bottom temperature

Challenges

Early detection of elevated temperatures in the bottom area of the melting tank caused by erosion of the refractory lining.

Advanced Energy's solution

Thermal imager for inspection of the melting tank bottom. By continuously monitoring surface temperature, the condition of the bottom refractory can be calculated and monitored, which enables the prevention of unexpected early failure.

Customer benefits

Early detection of wear in insulation materials allows for scheduling of corrective maintenance activities.

Prevention of glass runouts through the tank bottom, resulting in less frequent repairs and expensive stops in production.

Fixed-installation instruments at multiple locations

SOLUTIONS: thermal imaging, Series 520 pyrometers

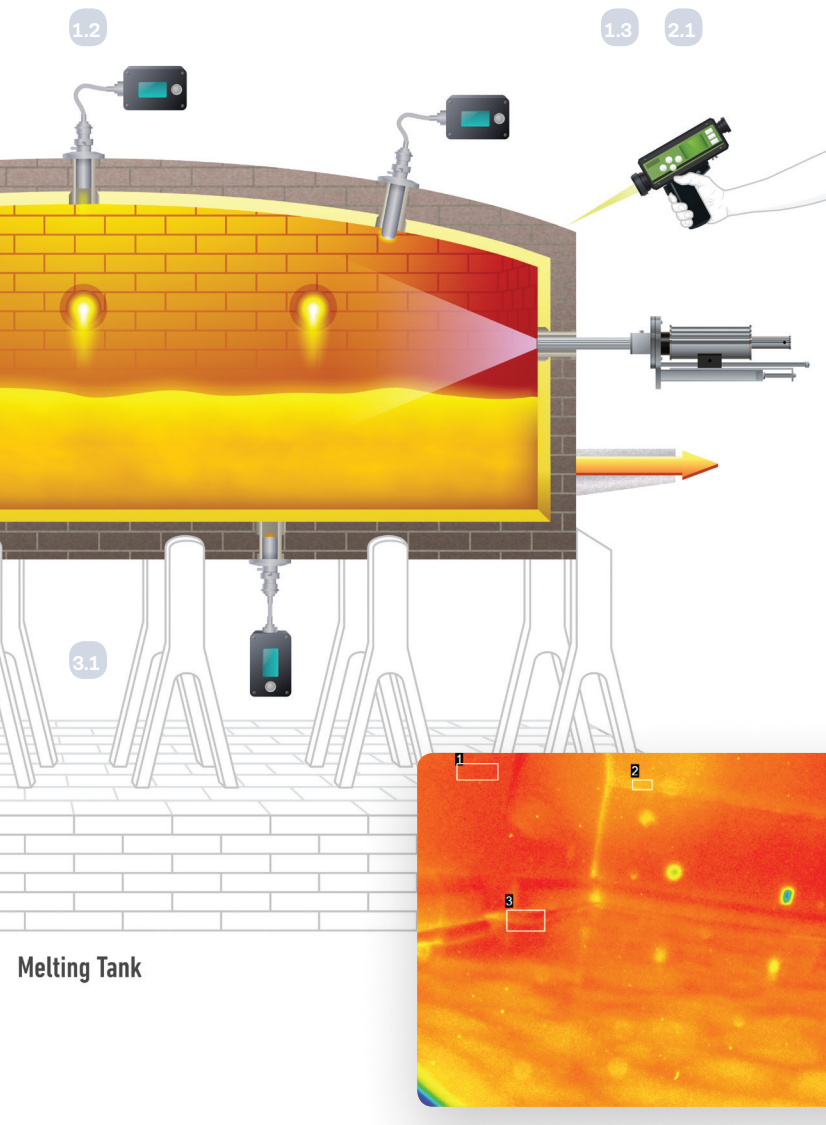
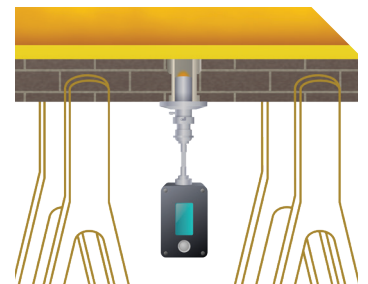

PROCESS STAGE

02 Monitoring the end-wall temperature

Challenges

Continuous measurement of end-wall temperatures for early detection of potential refractory failures.

Advanced Energy's solution

Robust handheld instrument with through-the-lens sighting for direct readings, high grade optics for detection of contours, and ultra-small measuring spots.

Alternative: Stationary measurement with IS 50-LO/GL

Customer benefits

Flexible inspection capabilities to monitor critical areas and prevent dangerous refractory failures at the end wall.



Mobile inspections

SOLUTIONS: Series 8 pro pyrometers for end-wall temperature

Flat Glass

Tin Bath

The tin bath is the key component in the modern float glass process. Molten glass from the melting tank enters the tin bath through a canal and floats on top of the molten tin.

Near the entrance of the controlled chamber, the temperature is kept high to allow the molten glass to spread and smooth out. The glass is then allowed to cool in the various heating/cooling zones. Ensuring proper temperature of these cooling zones is essential to maintaining uniformity.

Annealing Lehr

After the glass ribbon is properly formed, it is moved through the lehr. The lehr allows the glass to cool slowly for annealing. Thermal imagers have the advantage of being able to monitor a larger installation space to obtain optimal performance.

Considerable mechanical stresses may develop in the glass as it cools down. Advanced Energy supplies proven pyrometers and thermal imagers that enable optimum monitoring and control of the cooling rate of flat glass.

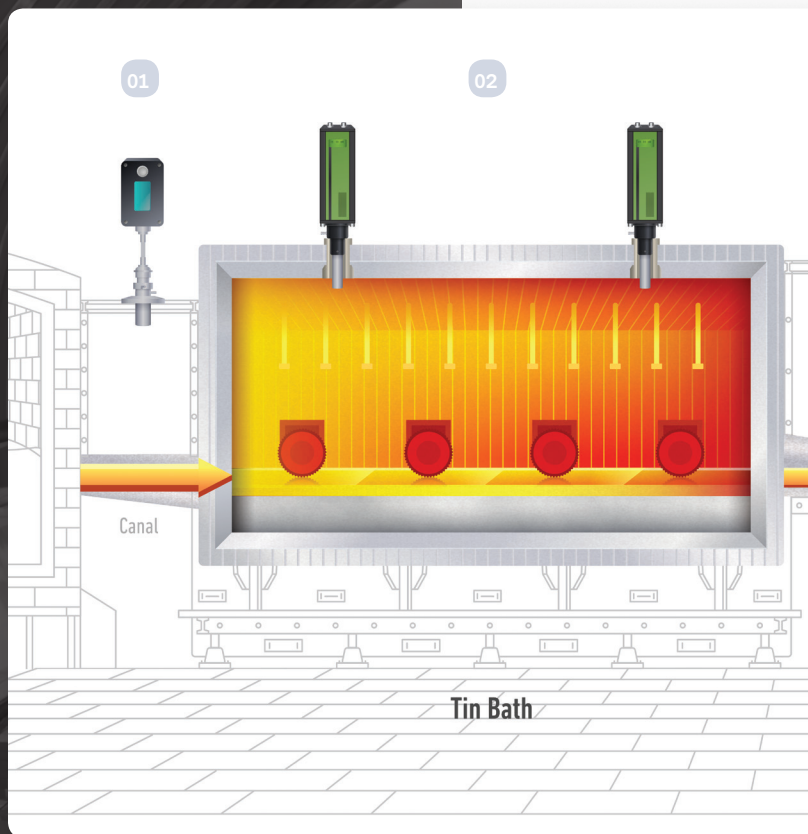

PROCESS STAGE

01 Reviewing the glass temperature in the canal

Challenges

Before the molten glass enters the tin bath, the optimum glass transition temperature must be present.

Advanced Energy's solution

A monitoring solution with a long fiber optic cable and open-ended ceramic or inconel tube as a radiation shield.

Customer benefits

Reliable adjustment of correct starting temperature for the complete down-stream process.

Adjustment of glass flow rate via its viscosity.

Cost reductions through closed-loop temperature control within tight tolerances.

SOLUTIONS:

Series 50-LO/GL pyrometers with open-ended ceramic or inconel tube

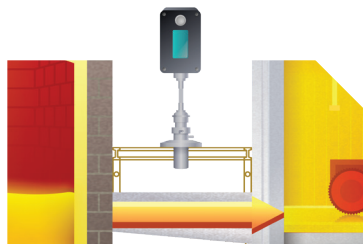

PROCESS STAGE

02 Measuring temperature distribution in the heating zone of the tin bath

Challenges

Ensure the requisite temperature distribution in the molten glass contained in the tin bath.

Advanced Energy's solution

A monitoring solution with an open-ended ceramic or inconel tube to shield the sensor against interfering radiation and to ensure the repeatability of readings.

Customer benefits

Reliable implementation of correct cooling rates and closed-loop control of heat input.

Cost reductions through optimized use of energy.

SOLUTIONS:

IPE 140/39 or IN 5/5 plus pyrometers



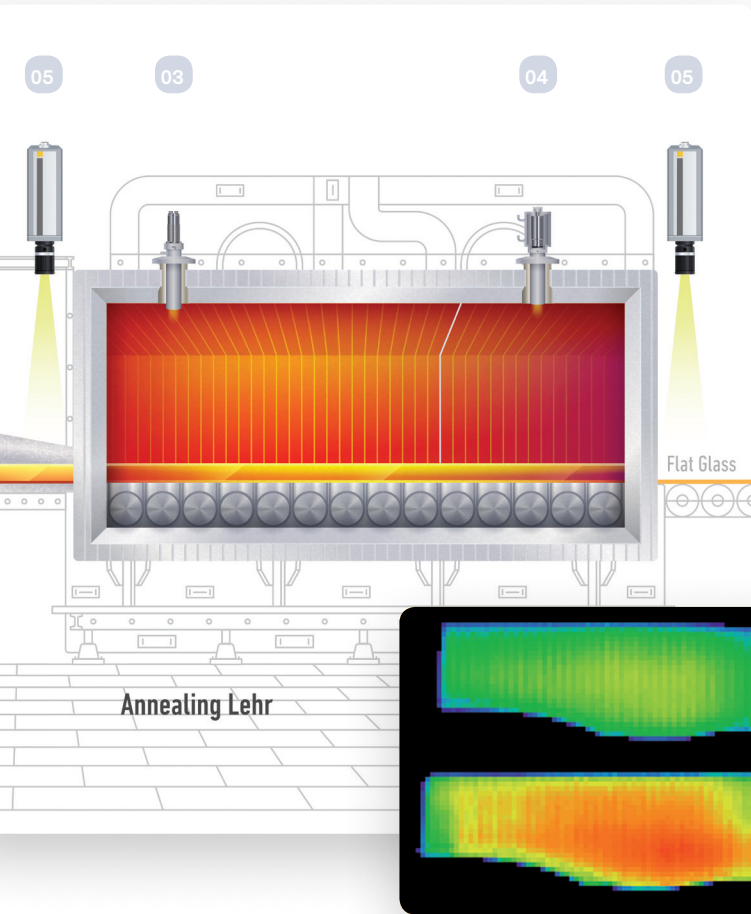

PROCESS STAGE

05 **Measuring the temperature distribution across the flat glass ribbon**

Challenges

Ensure homogeneous temperature distribution in the ribbon as the flat glass leaves the working tank.

Advanced Energy's solution

Thermal imagers for fast and full coverage temperature monitoring across the entire width of the flat glass ribbon.

Customer benefits

Rapid visualization of temperature distribution by means of thermal imaging software for easy, manual readjustment of heat input. Automatic alarms when limit values are exceeded.

SOLUTIONS:

Thermal imaging

← Thermal image of two glass panes

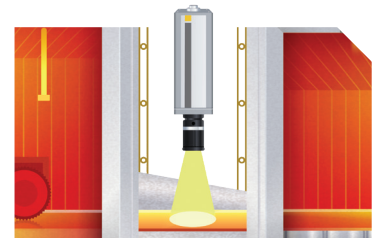

PROCESS STAGE

03 **Measuring surface temperatures in the annealing lehr**

Challenges

Relieve all mechanical stresses induced in the glass before further processing and packing. Process optimization through closed-loop control of the heating elements in the annealing lehr.

Advanced Energy's solution

Proven pyrometers with rugged sensors and a flat glass calibration feature tailored to the specific mounting conditions and ambient radiation.

Customer benefits

Closed-loop control of heating elements with accurate acquisition of flat glass temperature.

Quality assurance and efficient use of energy.

SOLUTIONS: Series 5/5 and 210/5 incl. special flat glass calibration and for ultra-thin glass sheets: IN 6/78-L

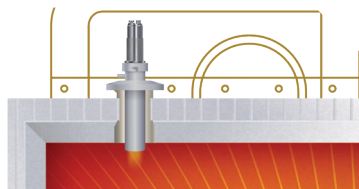

PROCESS STAGE

04 **Monitoring of annealing lehr discharge temperature**

Challenges

Ensure the requisite glass temperature after the cooling phase.

Advanced Energy's solution

A reliable low-temperature pyrometer in a stainless steel protective enclosure. Rugged two-wire system with analog signal transmission.

Customer benefits

Observance of correct material cooling rate for production of flat glass with few internal stresses.

Prevention of glass breakage due to thermal shock on entry into normal atmosphere.

SOLUTIONS: Series 5/5 incl. special flat glass calibration and protective enclosure

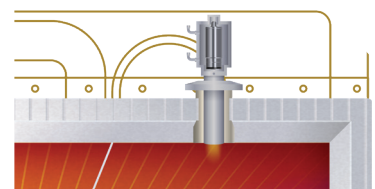

Container Glass



In the production of container glassware, closely controlled temperatures are key to shaping the glassware and to achieving energy savings. Advanced Energy's pyrometers and thermal imagers facilitate the adjustment of the temperature distribution and closed-loop control of the feeder temperature.

PROCESS STAGE

01 Measuring the temperature distribution in the working tank

Challenges

Ensure homogeneous temperature distribution in the molten glass exiting the working tank. Optimum adjustment of the temperature profiles in material flow direction.

Advanced Energy's solution

A monitoring solution with an open-ended ceramic or inconel tube to shield the sensor against interfering radiation and to ensure the repeatability of readings.

Customer benefits

- Reliable implementation of correct cooling rates.
- Adjustment of glass flow rate via its viscosity.
- Cost reductions through optimized use of energy.

PROCESS STAGE

02 Measuring the temperature gradient in the feeder

Challenges

Continuous measurement and control of the material flow. Minimized energy costs in the heating process.

Advanced Energy's solution

Proven application packages featuring high measuring accuracy, excellent repeatability and long service lives.

Customer benefits

- Quick installation thanks to easy and reliable integration of components.
- Optimized use of energy and adjustment of glass flow rate.

SOLUTIONS:

Series 50-LO/GL pyrometer with open-ended ceramic or inconel tube

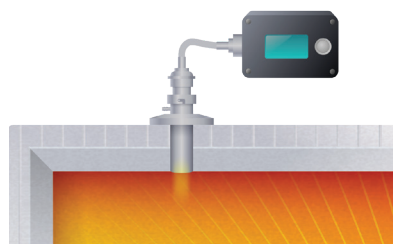

PROCESS STAGE

03 Measuring the gob temperature

Challenges

Ensure the desired container wall thickness via the core temperature of the gob.

Advanced Energy's solution

Rapid ratio pyrometer with small measuring spots.

Customer benefits

Reliably achieving the correct gob temperature prior to the next step in the process (IS machine).

SOLUTIONS:

Series 6 pyrometer including protective enclosure

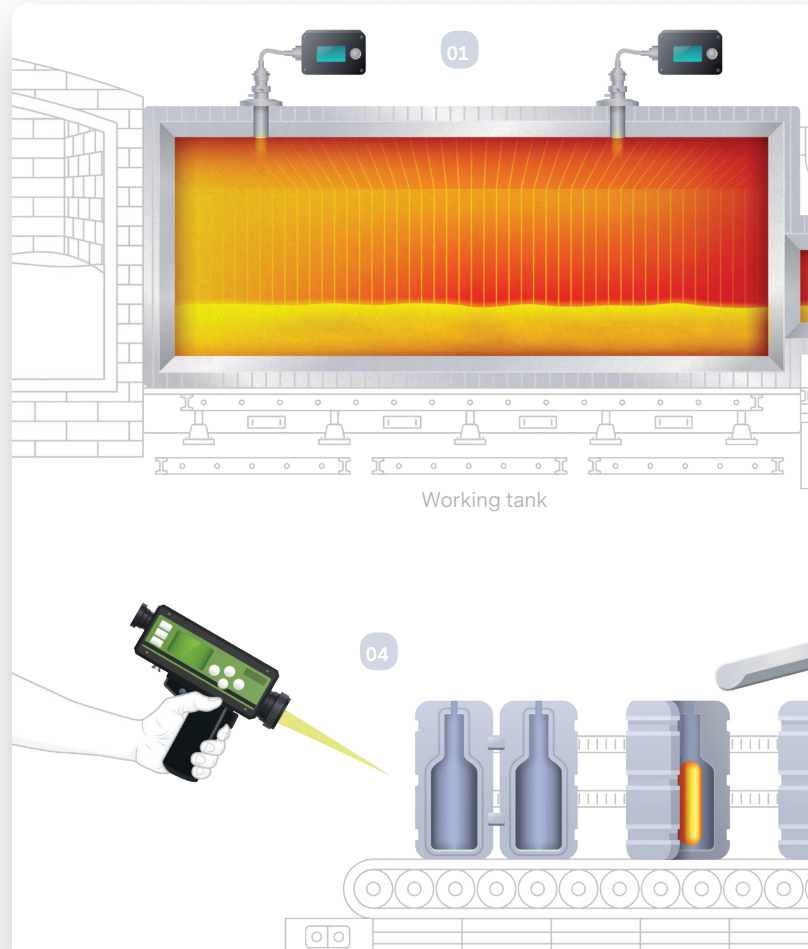
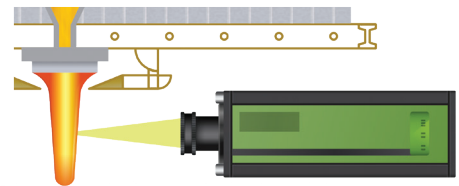

PROCESS STAGE

04 Measuring the mold temperature inside the IS machine

Challenges

Precise control of the air flow rate used for blowing and adjustment of the temperature distribution in the water-cooled mold. This forms the gob of glass into the desired shape with the requisite wall thickness.

Advanced Energy's solution

Portable pyrometer for mobile inspections or fixed installed pyrometer.

Customer benefits

- Optimum uniformity of container wall thickness.
- Optimum adjustment of coolants.

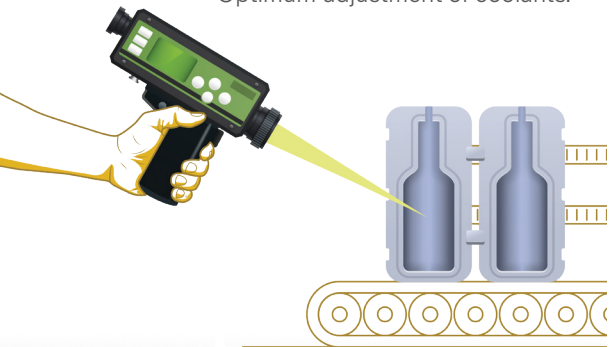

SOLUTIONS:

Series 15 (portable) or Series 6 (stationary) pyrometers

PROCESS STAGE

05 Final check and control of material distribution

Challenges

Save raw materials with a view to optimizing energy efficiency throughout the complete forming process.

Advanced Energy's solution

High resolution thermal imager with a spectral filter for glass surfaces and image processing software for automatic detection of defects.

Customer benefits

- General optimization of molds through visualization of glass wall thicknesses and localization of thin container walls.
- Automated mold parameter set-up through optional coupling of the system to the PLC for data correlation.

SOLUTIONS:

Thermal imaging

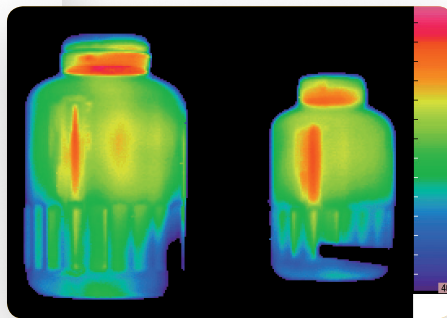
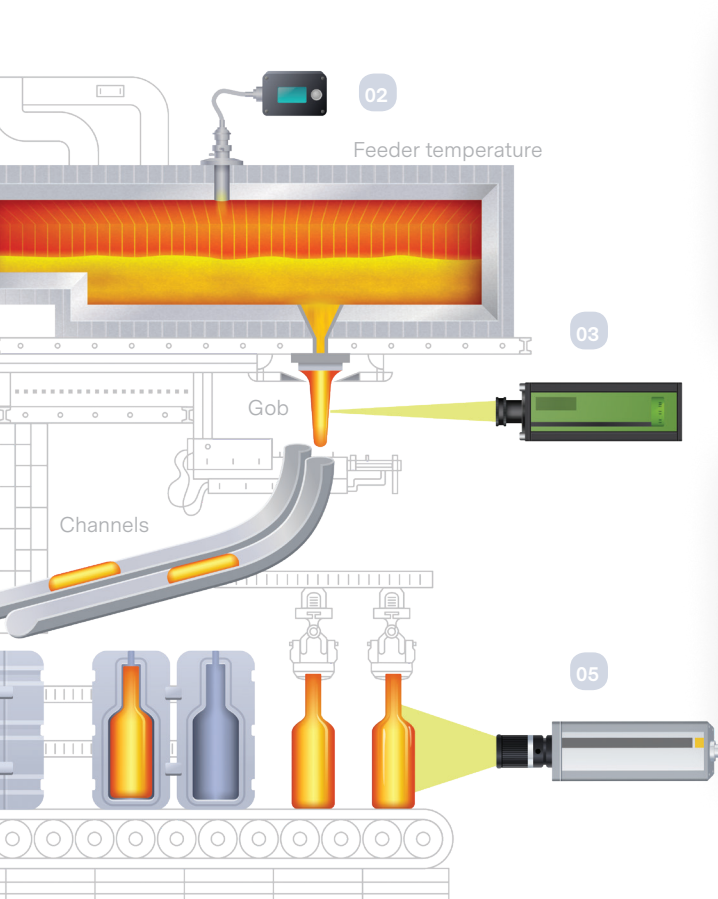
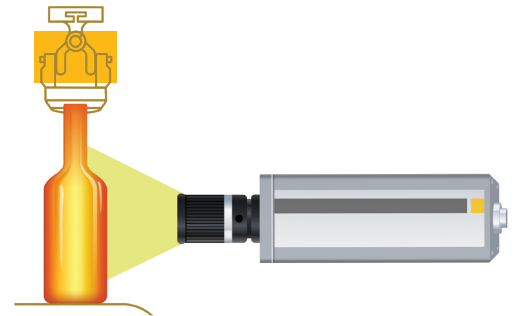

◀ Thermal image taken without spectral filter for glass surfaces. The interference from resulting ambient reflections causes direct measuring errors.

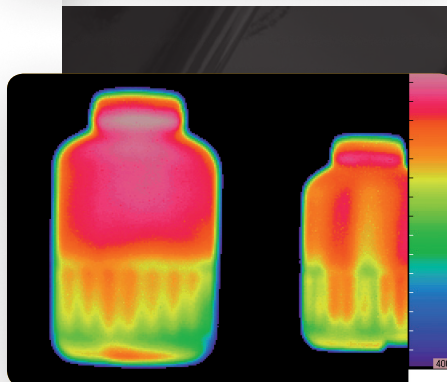

◀ Thermal image taken with spectral filter for glass surfaces at 5 μm. Ambient reflections are filtered out to minimize direct measuring errors.

Technical Glass

Manufacturing of technical glass is subject to particularly stringent quality requirements. The only way to achieve the desired quality and required service life of the product is to observe very close tolerances with regard to material temperatures throughout the entire process.

Pyrometers and thermal imagers from Advanced Energy are highly accurate temperature sensors and fulfill all prerequisites for successful compliance with quality requirements.

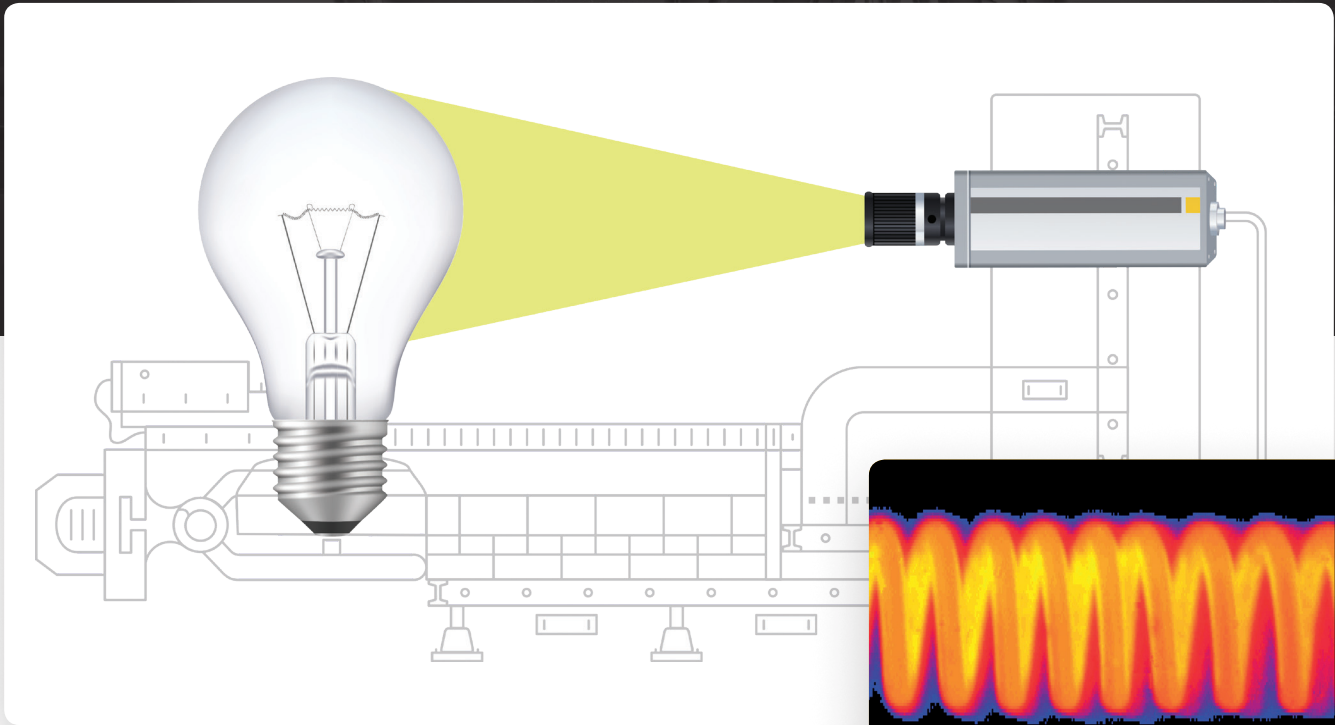

PROCESS STAGE

01 Measuring incandescent coils

Challenges

Optimization of temperature distribution in the incandescent coil.

Advanced Energy's solution

A fixed-installation thermal imaging system designed to measure very high temperatures on metals.

Real-time thermal imagery of temperature distribution and comprehensive data analysis and reporting features.

Customer benefits

Precise temperature measurements during the development phases of lamps and luminaires enable optimization of material properties and performance parameters.

This helps to considerably improve the service life of series production articles.

SOLUTIONS: Thermal imaging

SOLUTIONS FOR GLASS APPLICATIONS

PROCESS STAGE

02 Rotary blow-molding machine

Challenges

Detection of the glass mold temperature to ensure optimum shaping of the hollow glass body.

Advanced Energy's solution

Measurement of the glass mold temperature while the mold is open.

Customer benefits

Direct monitoring of the glass mold temperature and thus an exact control of the wall thickness of the glass body. The main advantage of monitoring the mold temperature is ensuring a constant shape of the glass item.

SOLUTIONS: Series 140, IGAR 320, and IGAR 6 Advanced pyrometers

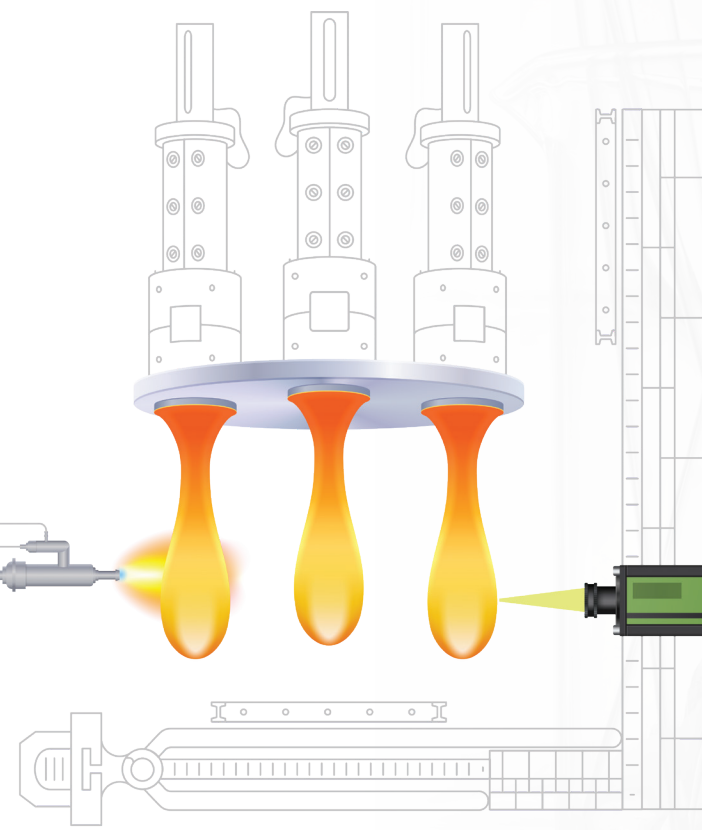

PROCESS STAGE

03 Measuring the temperature of glass dishes before entering the cooling lehr

Challenges

The temperature of the dishes must be measured to guarantee the desired material properties.

Advanced Energy's solution

Pyrometers for rapid data acquisition with small measuring spots and reliable data transfer. The use of a fast measuring instrument allows for scanning of a large number of measuring points on the dish as it passes on the conveyor.

Customer benefits

Optimized use of energy in the forming process and monitoring of dish temperatures.

SOLUTIONS: Series 140 pyrometers

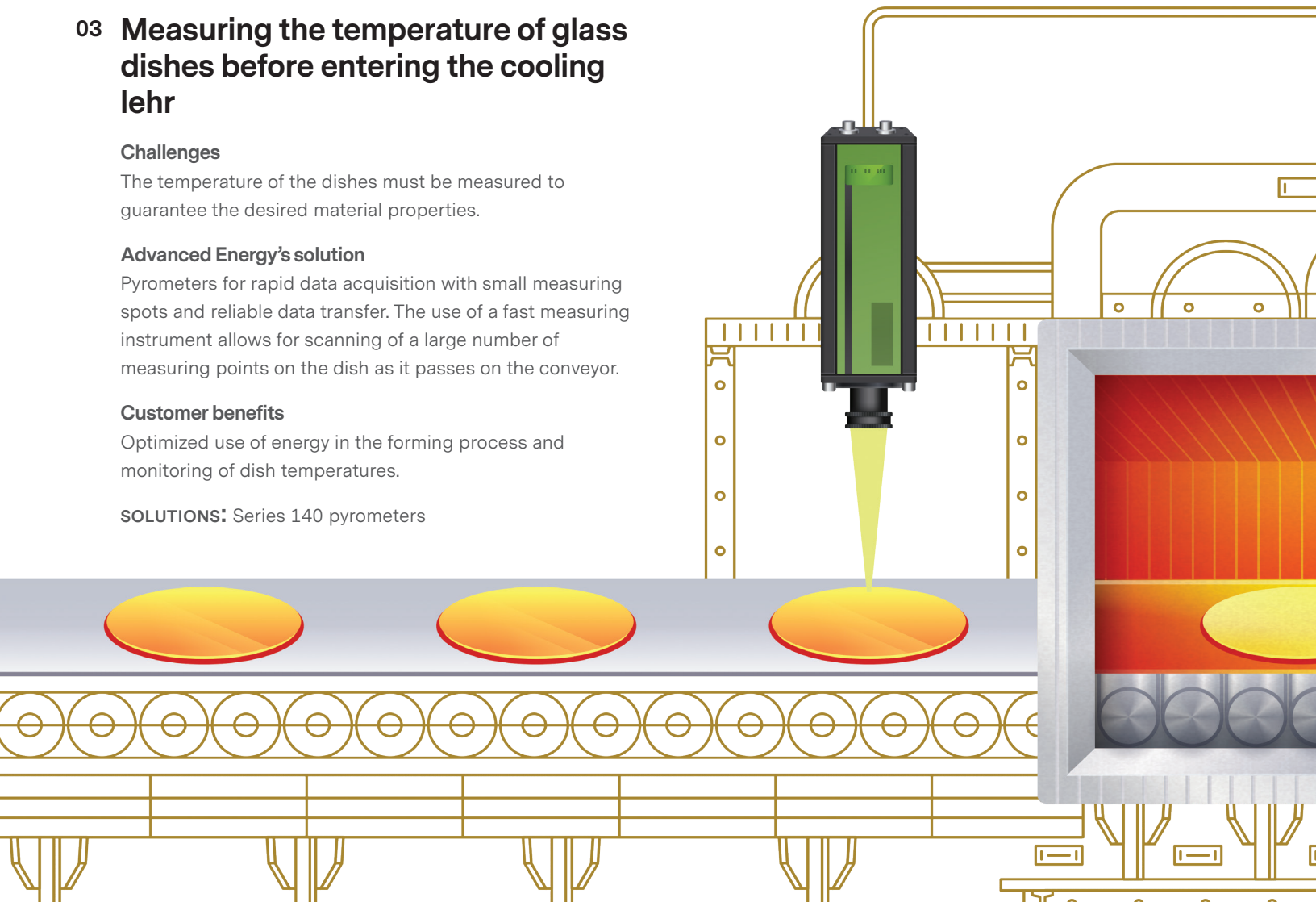

SOLUTIONS FOR GLASS APPLICATIONS

Our product lines include virtually hundreds of different non-contact temperature measuring instruments to suit nearly every industrial application. Using our comprehensive experience in this field, we have developed a wide range of high-end products specifically for the glass industry.

GLASS INDUSTRY SOLUTIONS

PYROMETERS

When you install our infrared detection instruments, you are investing in proven experience, superior performance, and trusted quality.

IN 5/5, IPE 140/39 & IN 140/5

Compact, highly accurate, fast digital pyrometers with variable focusing optics and integrated display.

The IN 5/5, IPE 140/39, & IN 140/5 are suitable for measuring the glass surface at the Tin float tank to control viscosity and temperature. The IN 140/5 and IN 5/5 can also be used in the Lehr bath and in the bending and heat treatment processes. The IPE 140/39 and IN 140/5 instruments features superior focusable optics while the IN 5/5 is an economical pyrometer with fixed optics.



Series 8

Rugged, high-end handheld units for medium to high temperatures



Series 520

Digital infrared pyrometers with temperature-resistant miniature sensor head (for up to 180°C)



Series 15

Portable, cost effective pyrometers for measuring tasks involving low to medium temperatures



Series 12

Extremely rugged industrial pyrometer for fixed installation in harsh environments



IN 6/78

Robust digital pyrometer designed for non-contact temperature measurement of the thinnest glass surfaces.

The IN 6/78 pyrometer uses a special 7.8 μm wavelength for non-contact temperature measurements on the thinnest (below 1 mm thickness) of glass surfaces accurately and reliably. The IN 6/78 also uses specially designed and coated high-end optics, which reduce the effects of ambient reflectance and guarantee the best possible accuracy.



Series 50-LO plus & IS 50-LO/GL

Digital infrared thermometer with fiber optic cable for industrial use.

The IS 50-LO/GL is designed for temperature measurement of bulk melt glass in the melt tank, working end, forehearth, and feeder. Series 50-LO plus instruments are also useful for the measurement of brickworks in the regenerator and melt tank. Using a robust fiber optic cable enables the use of the instrument in an ambient temperature up to 250°C without cooling.

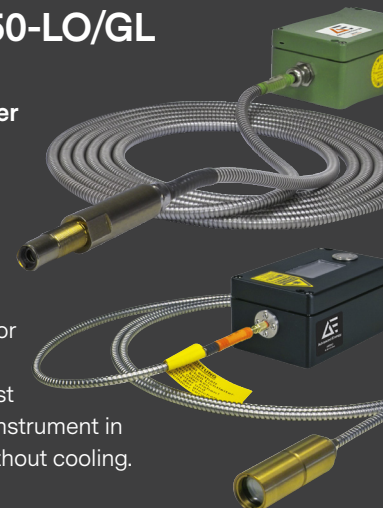

THERMAL IMAGING

Automated, continuous thermal and visual imaging to identify thermal abnormalities within industrial and petrochemical pipelines.

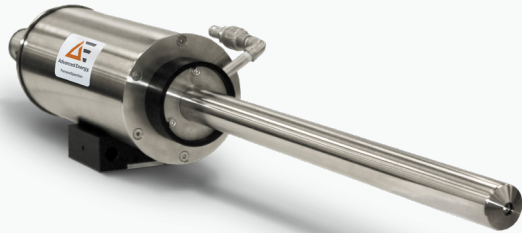

FurnaceSpection

Thermal imaging system designed for continuous monitoring inside a furnace.

FurnaceSpection is designed to continuously monitor through natural flames, the temperature of the liquid glass and refractory inside the melt tank. This system helps operators monitor and control process temperature uniformity through streaming images and powerful software for analysis and historical trending.

MC320 Series Thermal Imaging Camera

Thermal imagers for fixed-installation cameras for process quality monitoring.

- Temperature ranges between 150 and 1600°C
- Application-specific wavelength 3 to 5 μm , 3.9 μm , or 5 μm
- 9 to 60 frames per second, depending on the model
- User-friendly analysis programs and report generators (offline) as well as analysis and process control (online)



LumaSpec RT

Windows-based thermal imaging software that offers high-speed, real-time data acquisition and image analysis capabilities.

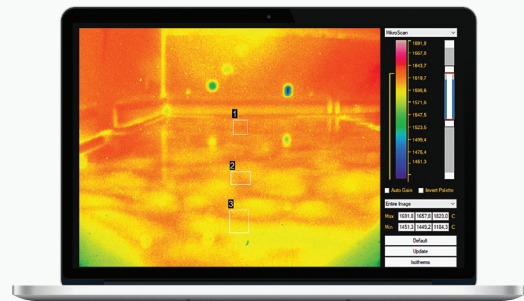

MC640 Series Thermal Imaging Camera

Thermal imagers for fixed-installation cameras for process quality monitoring.

- Temperature ranges between 600 and 3000°C
- Application-specific wavelength of 0.85 μm
- 60 frames per second
- User-friendly analysis programs and report generators (offline) as well as analysis and process control (online)





For international contact information,
visit advancedenergy.com.

sales.support@aei.com
+1 970 221 0108

ABOUT ADVANCED ENERGY

Advanced Energy (AE) has devoted more than three decades to perfecting power for its global customers. AE designs and manufactures highly engineered, precision power conversion, measurement and control solutions for mission-critical applications and processes.

AE's power solutions enable customer innovation in complex semiconductor and industrial thin film plasma manufacturing processes, demanding high and low voltage applications, and temperature-critical thermal processes.

With deep applications know-how and responsive service and support across the globe, AE builds collaborative partnerships to meet rapid technological developments, propel growth for its customers and power the future of technology.

PRECISION | POWER | PERFORMANCE

Specifications are subject to change without notice. Not responsible for errors or omissions. ©2019 Advanced Energy Industries, Inc. All rights reserved. Advanced Energy®, Impac®, Mikron®, and AE® are U.S. trademarks of Advanced Energy Industries, Inc.