



UltiMod

The UltiMod series from Excelsys - the Ultimate range of Modular Configurable Power Supplies

- **Unique in Flexibility**
- **Unrivalled in Performance**
- **Ultra Cost Competitive**



DESIGNERS' MANUAL

This UltiMod Designers' Manual has been prepared by Excelsys experts to assist qualified engineers and technicians in understanding the correct system design practices necessary to achieve maximum versatility and performance from any of the UltiMod products.

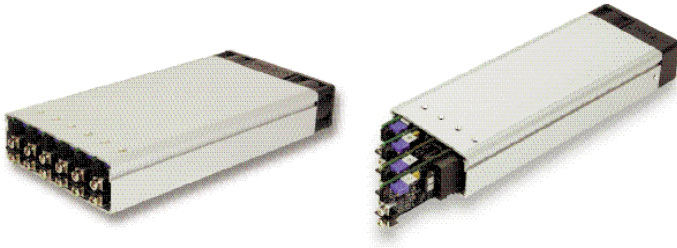

Section 4.1 Overview of UltiMod

The UltiMod series allows users to instantly configure high efficiency, off-line power supplies. Although very small in size, (40.4mm high, 260mm long and either 89mm or 127mm wide) the UltiMod provides up to 1200W of output power. The UX4 delivers up to 600W and can be populated with up to 4 *powerMods*, the UX6 delivers up to 1200W and can be populated with up to 6 *powerMods*.

A complete power supply is configured by selecting and inserting up to six DC output modules called *powerMods* to build a power supply that offers the advantages of a custom supply, but is assembled from standard and modular building blocks continuing the Excelsys tradition of industry leading configurable power supplies.

Manufactured in world class power supply facilities, the UltiMod is completely user configurable. If output requirements change, i.e. more power or a different output voltage is needed, upgrading is easy: simply unlock a single screw and replace the slide-in *powerMod* assembly with the preferred alternative. Allowing additional flexibility, *powerMods* can be connected in parallel to increase output power, or in series for higher voltages (subject to staying within isolation ratings and giving due consideration to any SELV requirements).

A user-friendly interface on connector J3 of each *powerMod* provides control and output sequencing capability, in addition to useful status indicators. Please consult our Excelsys applications team if you have other special requirements.

The plug-together architecture facilitates 'instant' custom power solutions with industry leading $17W/in^3$ power density and up to 92% conversion efficiency. The series is designed for highest efficiencies and consists of two Input AC front ends (*powerPacs*), UX4 and UX6 and 11 DC output *powerMods* (XgA to XgL).

Standard Features

- Input Voltage: 85V to 264Vac 47 to 63 Hz
- Outputs: Up to 12 isolated outputs
- Full power output to 40°C; Derating to 70°C

- Low inrush current
- Conducted EMI meets EN 55022 Level B
- AC Fail status signal
- Output sequencing capability
- Global shutdown capability
- Overcurrent protection standard on all outputs.
- Overvoltage protection on all outputs
- Over temperature limiting on all *powerMods* and *PowerPacs*
- Safety Agency Approvals: CE Mark, UL, CSA
- DC OK (Power Good) status signal (consult datasheet)
- Wide output voltage adjustment range
- RoHS compliant

Optional Features

- Reversed fan airflow direction
- Conformal coating
- Low leakage current

Section 4.2 Installation Considerations

The UltiMod series models may be mounted on any of three surfaces using standard M4 screws. The chassis comes with four mounting points on the base. Maximum allowable torque is 2Nm. The maximum penetration depth is 6mm. Additionally, the fleximount™ system on both side walls of the *powerPac* chassis facilitates flexible mounting.

When selecting a mounting location and orientation, the unit should be positioned so air flow is not restricted. Maintain a 50mm minimum clearance at both ends of the UltiMod power supply and route all cables so airflow is not obstructed. The standard unit draws air in on the input side and exhausts air out the load side. If airflow ducting is used, avoid sharp turns that could create back pressure.

Avoid excessive bending of output power cables after they are connected to the UltiMod *powerMods*. For high current outputs, use cable-ties to support heavy cables and minimise mechanical stress on output studs. Be careful not to short-out to neighboring output studs. UltiMod *powerMods* are supplied with spring washers on all output screws. These (or equivalents) should be used and thread locking compounds are not required. The maximum torque recommended on output connectors is 4Nm. Avoid applications in which the unit is exposed to excessive shock or vibration levels that exceed the specified levels. In such applications, a shock absorption mounting design is required.

Section 4.3 UltiMod Mounting Considerations

- Always fill all output slots of the UltiMod. If a slot is not filled with a *powerMod*, it should be filled with an Empty Slot Cover (part numbers XB1, XB2 or XB3). Empty Slot covers are plastic assemblies whose main function is to fill up an empty slot. Excessive airflow escape from an empty slot may degrade thermal performance and result in overheating and damage to the UltiMod unit. Refer to Section 4.11 for optimum positioning of *powerMods*.
- Do not unplug *powerMods* while input power is applied to the *powerPac*. The UltiMod is not designed for hot-plug applications.
- Do not restrict airflow to the unit. The cooling fan draws air into the unit and forces it out at the output terminals.
- Always ensure that output screws are properly torqued before

- applying power to the *powerPac*.
- Positive and negative power cables should be arranged as a twisted pair to minimise inductance.
- Wait 4 minutes after shutting off power before inserting or removing *powerMods*.
- UltiMod assemblies do not have user serviceable components. They must be returned to the factory for repairs. Contact Customer Service for a RMA number before returning the unit. Do not attempt to repair or modify the power supply in any manner other than the exchange of *powerMods* as described in this Designers' Manual.
- Use proper size wires to avoid overheating and excessive voltage drop.

Section 4.4 Theory of Operation

The UltiMod is comprised of an appropriate *powerPac* and a selection of *powerMod* DC output modules selected to deliver the exact volts and amps requirements of the the system designer. See Operational Block Diagram.

The UltiMod *powerPac* modules consist of a fan-cooled semi-enclosed chassis containing circuitry for an off-line single phase AC front end, EMI filter, cooling fan, customer interface and associated housekeeping circuits. Input AC mains voltage (L1/N, L2 and GND) is applied to an IEC320 type input connector and then through an EMI filter designed to meet EN 55022 Level B. For medical applications, the EMI filter also ensures the power supply meets the low earth leakage current requirements of EN60601-1 3rd Edition.

Inrush current limited by an active soft start cct. Current is limited by a combination of thermistors (UX4), and thermistors and SCR's (UX6). This stage is then followed by a high frequency switching input current shaping boost converter feeding the ZVS (Zero Voltage Switching) resonant switching stage. The ZVS stage supplies power to a variety of *powerMod* assemblies that provide the desired low voltage, regulated outputs. Conversion in the output assemblies is achieved by the most advanced high efficiency converters resulting in reduced

size for magnetics and capacitors; excellent line and load regulation; wide adjustment range for output and low EMI/RFI emission.

At initial power-up, the UltiMod outputs are disabled to eliminate inrush current and a low-power flyback converter operating with PWM current mode control converts the high voltage DC bus into regulated low voltage to power the internal housekeeping circuits and cooling fans. Once the bus potential is within operating parameters, the AC Fail signal is activated indicating that the input power is ok, and allows the installed *powerMod* outputs to come up. An auxiliary bias supply of 5 Vdc is provided for peripheral use on interface connector J2. In the case of medically approved supplies, this bias supply has medical isolation (4000VAC).

Section 4.5 Configuration (and Reconfiguration)

powerMods may be easily added, replaced, or moved by sliding the assemblies in or out of a *powerPac* chassis.

Prior to removing or installing a *powerMod* module, remove power from the *powerPac* and wait 4 minutes. Failure to do so can result in personal injury and/or damage to the supply. Take standard ESD precautions when handling *powerMods*.

Configuring the UltiMod is as easy as 1,2,3!

1. Select the appropriate *powerMods* for your application.
2. Calculate your power requirements.
3. Select your appropriate *powerPac* for power and application from the wide range of *powerPacs*.

Removing *powerMods*

powerMods may be removed by removing the screw on the top surface. Once this screw has been removed the *powerMod* will slide out of the chassis. Once a *powerMod* has been removed, the empty slot MUST be filled with either another *powerMod* or an empty slot cover. If the slot is left empty, it will provide an airflow escape and may cause inadvertent shutdown of the unit.

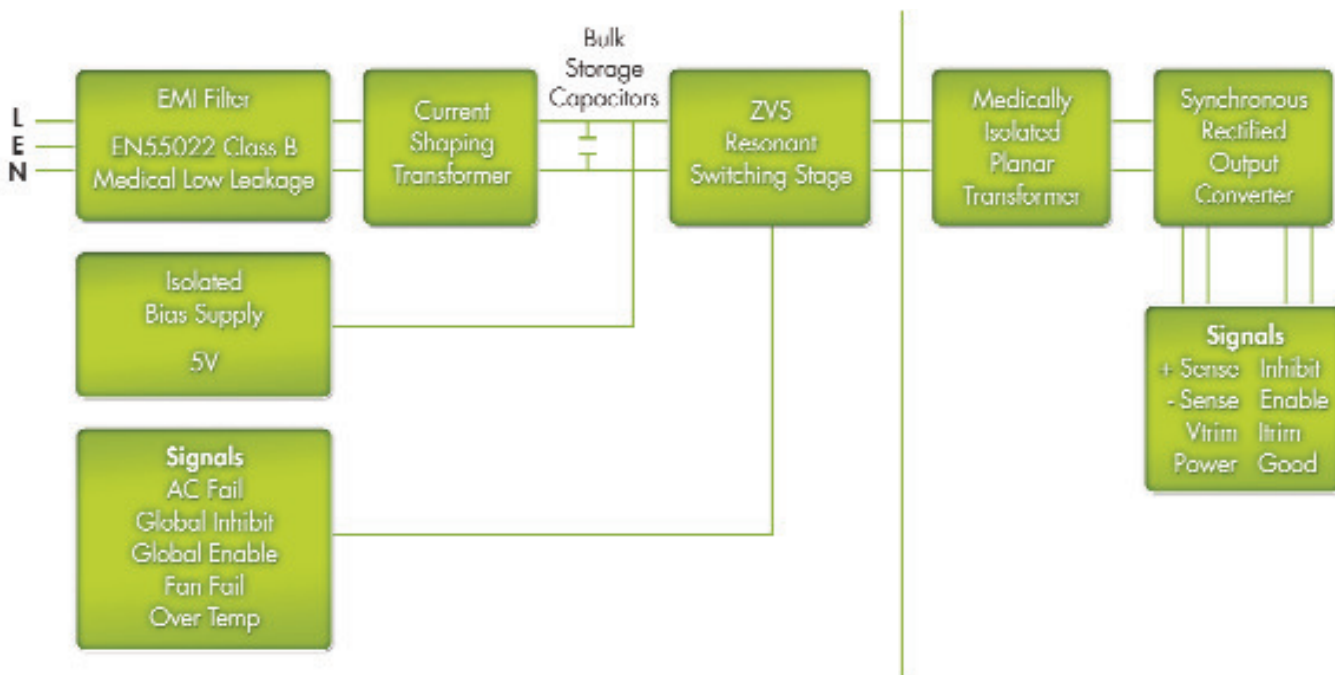

Operational Block Diagram

Installing powerMods

powerMods may be installed in empty slots by simply sliding in the new powerMod, pushing the module 'home' until the mounting bracket lines up with the hole in the Top Panel, then securing the module with the M3 x 6 countersunk screw provided. Power and interface connections can be made after the powerMod has been installed.

powerMods may be paralleled for more power using bus bars (Paralleling Links) across the positive and negative output terminals. See Section 4.6 for details.

Section 4.6

powerMod Operation

The UltiMod has been designed to allow maximum flexibility in meeting the unique requirements of individual users. The inherent flexibility resulting from modularity concepts is further enhanced by this flexibility. Although the products are very versatile, care should always be taken to ensure that the proper procedures are followed.

Voltage Adjustment

The UltiMod has been designed with maximum user flexibility as a key objective. With regards to voltage adjustment this has been achieved by the wide range of adjustment on each of the powerMod models. Voltage adjustment may be achieved by:

1. Front-panel potentiometer adjustment (XgA - XgL)
2. Remote resistive programming (XgG - XgL)
3. Remote voltage programming (XgG - XgL)

See diagrams for details on external connections to the V trim pin (J3 pin3) required for remote voltage programming(XgG - XgL).

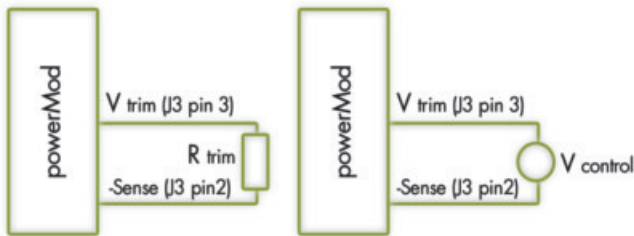

Remote Output Voltage Adjustment of powerMods

Remote Voltage Programming using a Voltage Source

Using an external Voltage source ($V_{control}$), the powerMod output voltage may be adjusted over a wide range. The powerMod output voltage may be programmed by referring to the Voltage Programming Graph and applying the formula below to set the powerMod output voltage to the required level.

$$V_{output} = K \times V_{control} \tag{1}$$

The appropriate K factor for different powerMods are in the 'Remote Output Voltage Adjustment' table.

Important: $V_{control}$ must not exceed 2.5V.

Example.

Using a powerMod XgK, what external voltage must be applied to Vtrim pin in order to set powerMod output voltage to 20V.

$$V_{output} = 20V, K=12.5$$

$$\text{Using equation (1); } V_{output}/K=V_{control}$$

$$20V/12.5 = 1.6V.$$

$$V_{control} = 1.6V$$

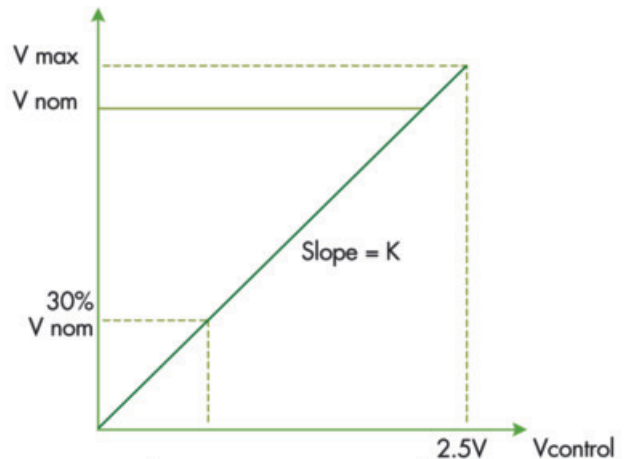

Remote Output Voltage Adjustment of powerMods

| powerMod | K |
|----------|------|
| XgG | 1.56 |
| XgH | 2.5 |
| XgJ | 6.23 |
| XgK | 12.5 |
| XgL | 24.2 |

Remote Output Voltage Adjustment Table

Remote Voltage Programming using a Resistor.

The powerMod output voltage can be adjusted downward using a remote potentiometer or reduced, using an external resistance.

Calculation of the the external resistance depends on the actual initial voltage setting of the powerMod (via the onboard potentiometer). The preferred method is to set the powerMod voltage to its maximum rating. e.g. XgK set to 30V. This will allow the widest possible adjustment range of the output voltage.

powerMod set to V_{max}

$$R_{trim} = \frac{[3700V_{out} - 250K]}{[2.5K - V_{out}]} \tag{2}$$

Example.

Using a powerMod XgK, determine the resistance value to be applied to Vtrim pin in order to set powerMod output voltage to 20V.

$$K \text{ for XgK} = 12.5$$

$$V_{out} = 20V$$

Using equation (2)

$$R_{trim} = 6300 \text{ ohm}$$

Alternatively if the powerMod voltage is set to new level via the on-board potentiometer to another level e.g. 21V then the following formula must be used to calculate the value of R_{trim}

| Model | Vnom (V) | Set Point Adjust Range (V) | Current Limit Foldback | Dynamic Vtrim Range (V) | I _{max} (A) | Power (W) | OVP 1 Tracking % of Vset | Remote Sense (V) | Power Good |
|-------|----------|----------------------------|------------------------|-------------------------|----------------------|-----------|--------------------------|------------------|------------|
| XgA | 12.0 | 10.8-15.6 | - | - | 12.5 | 150 | - | - | - |
| XgB | 24.0 | 19.2-26.4 | - | - | 8.3 | 200 | - | - | - |
| XgC | 36.0 | 28.8-39.6 | - | - | 5.6 | 200 | - | - | - |
| XgD | 48.0 | 38.5-50.4 | - | - | 4.2 | 200 | - | - | - |
| XgE | 24.0 | 5.0-28.0 | No | - | 5.0 | 120 | No | - | Yes |
| XgF | 24.0 | 5.0-28.0 | No | - | 3.0 | 72 | No | - | Yes |
| | 24.0 | 5.0-28.0 | No | - | 3.0 | 72 | No | - | Yes |
| XgG | 2.5 | 1.5-3.6 | Yes | 1.0-3.6 | 40.0 | 100 | 110-115% | 0.5 | Yes |
| XgH | 5.0 | 3.2-6.0 | Yes | 1.5-6.0 | 36.0 | 180 | 110-115% | 0.5 | Yes |
| XgJ | 12.0 | 6.0-15.0 | Yes | 4.0-15.0 | 18.3 | 220 | 110-115% | 0.5 | Yes |
| XgK | 24.0 | 12.0-30.0 | Yes | 8.0-30.0 | 9.2 | 220 | 110-115% | 0.5 | Yes |
| XgL | 48.0 | 24.0-58.0 | Yes | 8.0-58.0 | 5.0 | 240 | 110-115% | 0.5 | Yes |

Output powerMod Summary Specifications

$$R_{trim} = \frac{1000V_{out} [(4.275 + Vp(1.96-4Vp)) - K(0.1Vp+0.051)]}{K(Vp + 0.51) - 0.604V_{out}} \quad (3)$$

where V_p is the powerMod setpoint voltage expressed as a proportion of the total trim range and can be calculated using formula (4).

$$V_p = \frac{(V_{set} - 0.844K)}{1.656K} \quad (4)$$

Example.
To set powerMod XgK to 15V when powerMod Vset is 21V.
K=12.5

$$\begin{aligned} \text{Using equation (4)} \quad V_p &= \frac{V_{set} - 0.844K}{1.656K} \\ &= \frac{21 - 0.844(12.5)}{1.656(12.5)} \end{aligned}$$

$$V_p = 0.5048$$

$$V_{out} = 15V$$

$$\begin{aligned} \text{Using equation (3)} \\ R_{trim} &= \frac{1000V_{out} [(4.275 + Vp(1.96-4Vp)) - K(0.1Vp+0.051)]}{K(Vp + 0.051) - 0.604V_{out}} \end{aligned}$$

$$R_{trim} = 17,212 \text{ ohm}$$

The power rating of the trim resistor can be as low as 100mW

Over Current Protection (OCP)

A variety of over current protection methods are possible with the Ultimod series. See the 'Output powerMod Summary' table which indicates the available current limit modes on each powerMod.

powerMods XgG to XgL can have Straight-line current limit or Foldback current limit. See 'Output powerMod Summary Specifications' table for nominal current limit values.

Simple external application circuits may be used to achieve programmable foldback current and user programmable current limit levels (reduced). See Current Limit Programming

diagrams and Foldback Programmable Current Limit diagram. The default current limit characteristic is Straight Line Current Limit.

Programming Current Limit

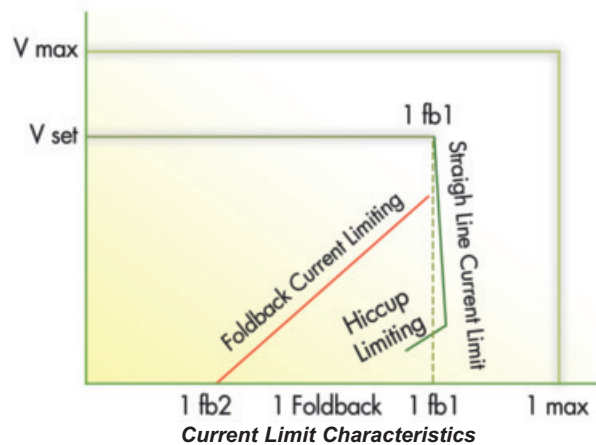

The current limit can be programmed to your requirements (in both Straight line and Foldback modes).

Straight line Current Limit can be programmed using an external voltage source or resistor/potentiometer. Connection between the Itrim pin (J3 pin4 and the -Vout terminal) will set the current limit to the desired level.

Straight Line Current Limit Using a Voltage Source

The formula below will calculate the required external control voltage required to set the current limit of a powerMod:

If Current Limit is Less than 85% of Maximum Current

$$I_{trim} = F I_{lim} + CF - 0.53 \quad (5)$$

If Current Limit is Greater than 85% of Maximum Current:

$$I_{trim} = \frac{F I_{lim} + CF - 1.325}{0.558} \quad (6)$$

Where F is a conversion factor for each powerMod and CF is a correction factor.

Example:
To set the current limit of XgH to 20A, determine the external voltage to be applied to the I_{trim} pin.

I_{lim} = 20A
F = 0.0468 for XgH
CF = 1.043 for XgH
I_{max} = 36A for XgH (I_{max} = max current rating of XgH)

$$\frac{I_{lim}}{I_{max}} = \frac{20}{36} = 55.5\% \text{ (less than 85\%)}$$

Using equation (5)

$$I_{trim} = F I_{lim} + CF - 0.53$$

$$I_{trim} = 1.45V$$

Note that application of any voltage >2.5V to I_{trim} will not increase current limit beyond the powerMods normal current limit.

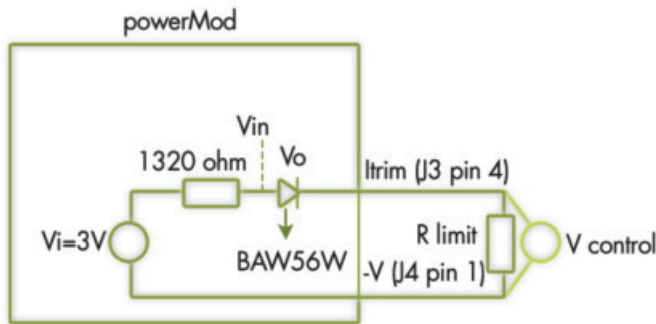

Current Limit Programming

| powerMod | F | CF |
|----------|--------|-------|
| XgG | 0.0395 | 1.12 |
| XgH | 0.0468 | 1.043 |
| XgJ | 0.0933 | 1.015 |
| XgK | 0.1742 | 1.009 |
| XgL | 0.3182 | 1.065 |

Current Limit Adjustment Table

Straight Line Current Limit Using an External Resistor

The formula below will calculate the required external resistor value required to set the current limit of a powerMod:

If Current Limit is Less than 85% of Maximum Current:

$$R_{Itrim} = \frac{1320 \cdot I_{trim}}{2.47 - I_{trim}} \tag{7}$$

If Current Limit is Greater than 85% of Maximum Current:

$$R_{Itrim} = \frac{1320 \cdot I_{trim}}{1.675 - 0.558 I_{trim}} \tag{8}$$

Example:

To set the current limit of XgH to 30A, what resistance must be placed between the I_{trim} pin and -V.

I_{lim} = 30A
F = 0.0468 for XgH
CF = 1.043 for XgH
I_{max} = 36A for XgH

$$\frac{I_{lim}}{I_{max}} = \frac{20}{36} = 55.5\% \text{ (less than 85\%)}$$

Using equation (5)

$$I_{trim} = F I_{lim} + CF - 0.53$$

$$I_{trim} = 1.45V$$

Using equation (7)

$$R_{Itrim} = \frac{1320 \cdot I_{trim}}{2.47 - I_{trim}}$$

$$R_{Itrim} = 1,873\text{ohms}$$

Foldback Current Limit Programming

Foldback Current Limit can be achieved using the circuit below.

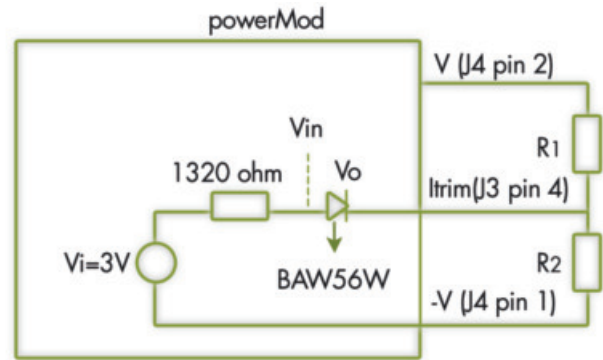

Foldback Current Limit

The onset of Foldback current limit (I_{fb1}) can be programmed using the formula below as can the actual end point (I_{fb2}). To set the final Foldback current limit point (I_{fb2}), the value R₁ in parallel with R₂ is equivalent to R_{Itrim} in the previous Straight Line current limit example.

To set I_{fb1}, point, we must calculate the ratio of R₁ to R₂. To get the value of R₁:

$$R1 = \frac{(R_{Itrim})V_{out}}{[F I_{fb1}(1 + \frac{R_{Itrim}}{1320}) - 2\frac{R_{Itrim}}{1320} + 1 - VD]} \tag{9}$$

$$R2 = \frac{(R1)(R_{Itrim})}{R1 - R_{Itrim}} \tag{10}$$

VD is the voltage drop across BAW56W. This can be assumed to be 0.53V for most calculations, however it will vary slightly due to temperature. Refer to BAW56W datasheet for further details.

If Current Limit is Less than 85% of Maximum Current:
VD=0.53 (11)

If Current Limit is Greater than 85% of Maximum Current:
VD=1.325 - 0.442 I_{trim} (12)

Example:

To set the foldback current limit of an XgH set at 5V to the following levels, I_{fb1} =30A and I_{fb2}=30A, determine the values of R₁ to R₂ required.

F = 0.0468 for XgH
CF = 1.042 for XgH
I_{max} = 36A for XgH
 $\frac{I_{lim}}{I_{max}} = \frac{20}{36} = 55.5\% \text{ (less than 85\%)}$
I_{max} = 36

Using equation (5) $I_{trim} = F_{lim} = CF - 0.53$
 $I_{trim} = 1.45$

Using equation (7) $R_{ltrim} = \frac{1320 I_{trim}}{2.47 - I_{trim}}$
 $R_{ltrim} = 1,873 \text{ ohms}$

To calculate the ratio of R1 to R2 use the formula above

Use equation (11) to get the value of VD
 $VD = 0.53$

Use equation (9) to get the value of R1

$$R1 = \frac{R_{ltrim} V_{out}}{F_{fb1} (1 + \frac{R_{ltrim}}{1320}) - \frac{2R_{ltrim}}{1320} + 1 - VD}$$

$R1 = 9110 \text{ ohm}$

Use equation (10) to get the value of R2

$$R2 = \frac{(R1)(R_{ltrim})}{R1 - R_{ltrim}}$$

$R2 = 2358$

Over Voltage Protection (OVP)

Over-voltage protection is implemented on each *powerMod* output. OVP level is fixed relative to V_{max} (110-125%). OVP is Latching and it may be reset by removing and reinstating AC power from the *powerPac* input.

Power Limit

Each *powerMod* has a number of levels of protection in order to ensure that *UltiMod* is not damaged if used in overload conditions. See graph.

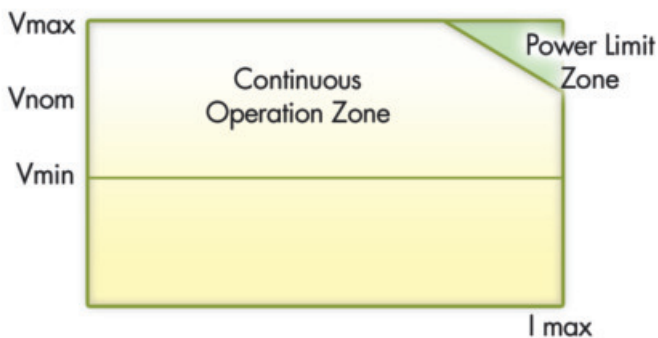

Output powerMod Power Limit

When V_{set} is less than or equal to V_{nom} , current limit is employed at the current limit set point. However if V_{set} is greater than V_{nom} , the power limit is employed to ensure that the *powerMods* does not exceed its power rating.

e.g. XgK is adjustable between 12V and 30V. I_{max} is 9.2A. Power rating is 220W.

At 24V the *powerMod* can deliver 9.2A continuously, i.e 220W. At 30V, the *powerMod* can still deliver 220W, however this equates to 7.33A continuous.

Remote Sense

To compensate for voltage drops in the output leads, use remote sensing. Remote sensing is available on all single output and on the first output (V1) of the dual output module.

Remote sensing may be implemented by connecting the Positive Sense pin (J3 pin1) to the positive side of the remote load and the Negative Sense pin (J3 pin2) to the negative side of the remote load. The maximum line drop, which can be compensated for by remote sensing, is 0.5V, subject to not exceeding the maximum module voltage at the output terminals.

Observe the following precautions when remote sensing:

1. Use separate twisted pairs for power and sense wiring.
2. Route the sensing leads to prevent pick up, which may appear as ripple on the output.
3. Never disconnect the output power rail with the sensing still connected to the load.

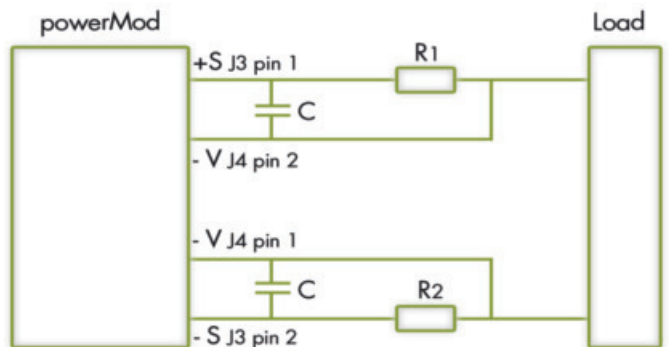

Remote Sense of Output Voltage

In certain applications where there is a high dynamic impedance along the power leads to the sensing point, remote sensing may cause system instability. This system problem can be overcome by using resistors in the sense leads (Positive sense lead: $R1 = 100\text{ohm}$, Negative sense lead: $R2=10\text{ohm}$), together with local AC sensing, by using 22uF capacitors between the remote sense pins and the output terminals.

The resistance of the power cables must be so that the voltage drop across the cables is less than 0.5V (to ensure remote sensing operates correctly).

$$R_{cable} < \frac{0.5}{I_{out}}$$

e.g. for an XgH, 5V/36A. The R_{cable} must be less than 12.5mohms.

Measurement of Ripple & Noise

As with all switched mode power supplies, it is important to ensure that the correct method is used to verify ripple & noise. Care should be taken to ensure that a loop antenna is not formed by the tip and ground lead of the oscilloscope probe as this would lead to erroneous readings consisting mainly of pickup from remnant radiation in the vicinity of the output connectors. Excelsys recommends the use of a x1 probe with the ground sheath of the probe tip used for ground connection.

In some applications, further erroneous readings may result from CM currents. These can be reduced by looping a few turns of the scope lead through a suitable high permeability ferrite ring.

As most loads powered by a power supply will have at least small values of differential capacitors located near the load, Excelsys also recommends the use of small value of capacitance (approx 1uF) positioned at the point of measurement.

Minimising System Noise

There are a number of causes of poor system noise performance. Some of the more common causes are listed below.

- a. Insufficient de-coupling on the PCB or load.
- b. Faulty wiring connection or poor cable terminations.
- c. Poor system earthing.

There are some simple steps to eliminate, reduce or identify the causes of high frequency noise,

- a. Is the noise conducted or radiated? If changing the position of the power supply or screening improves performance, the noise is likely to be radiated. See Section 4.14 EMC (Electro Magnetic Characteristics).
- b. Twist all pairs of power and sense cables separately.
- c. Ground connections (zero Volt) should be made with the shortest possible wiring via a capacitor to the nearest point on the chassis.

powerMod Start-Up and Shutdown

powerMods are designed such that when input power is applied, all outputs rise to their set point voltage simultaneously. Likewise, when input power is removed all outputs commence to drop simultaneously and reach Zero potential simultaneously.

Outputs can be sequenced using the enable function in order to allow controlled start up if required.

See plots for start-up and shutdown characteristics.

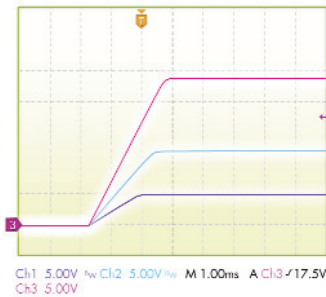

Output powerMod Start-Up

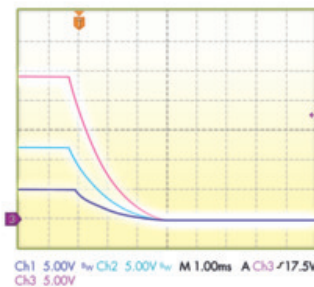

Output powerMod Shutdown

Section 4.7

Mechanical Section

Input Connectors

The UltiMod series has a variety of input connector options to ease system integration. These include IEC, Input cables (3-wire) and IEC to Screw Terminal Adaptor.

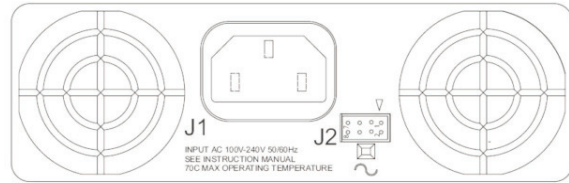

| Pin | J1 | J2 |
|-----|---------|----------------|
| 1 | Line | Common |
| 2 | Neutral | +5V Bias |
| 3 | Earth | not used |
| 4 | | AC Fail |
| 5 | | Fan Fail |
| 6 | | Global Enable |
| 7 | | Temp Alarm |
| 8 | | Global Inhibit |

Input Mating Connectors

J1: IEC320 type female plug rated 13, Locking IEC cable and connector: Schaffner EMC part number IL13-US1-SVT-3100-183. J2: Locking Molex 51110-0860; Non Locking 51110-0850; Crimp Terminal: Molex p/n 50394

Input Cable (Option D)

The UltiMod Series is also available with an input cable connection option allowing greater flexibility when mounting the UltiMod in the system. Input cables are 300mm in length and come supplied with Faston connectors.

IEC to Screw Terminal Adaptor

Some applications may require a screw terminal input rather than the standard IEC320 connector provided with the UltiMod. For such applications, Excelsys can offer the XE1, the IEC to Screw terminal adaptor accessory plug. This is a press fit connector that plugs securely into the UltiMod powerPac and provides the system integrator with screw terminals for mains connection.

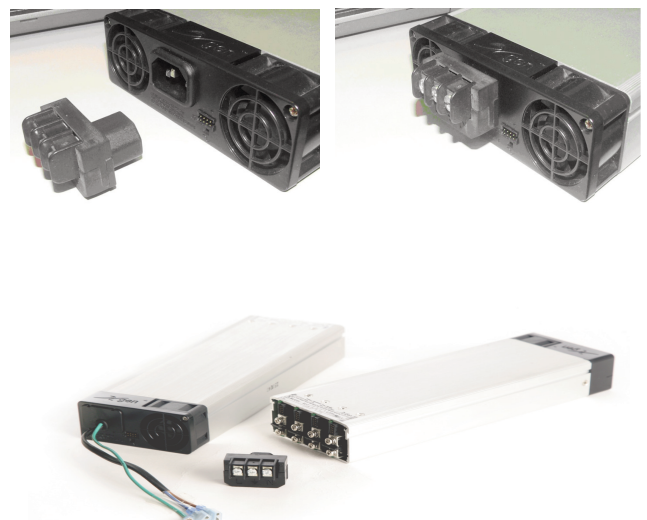

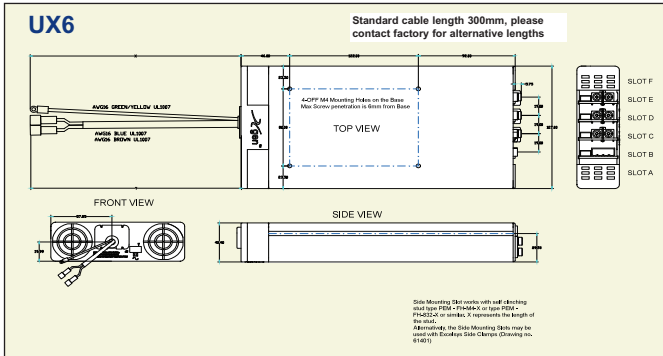
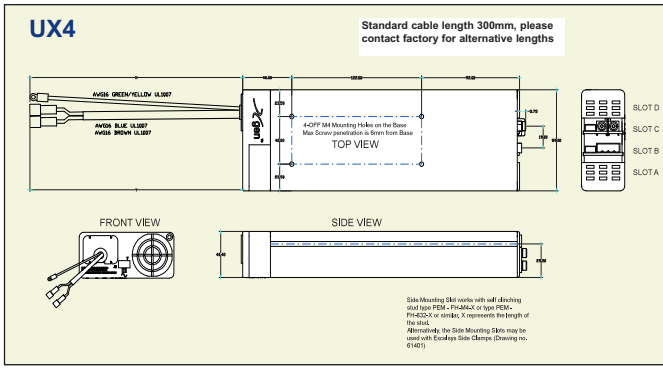

Output Connectors

The output *powerMods* connection details are shown below. Type A connectors are for single output *powerMods* XgA to XgL. The Type B connector is for the Dual output XgF *powerMod*. The power and signal connectors are as follows:

Type A: *powerMods* XgA to XgE XgG to XgL

Type B: *powerMod* XgF

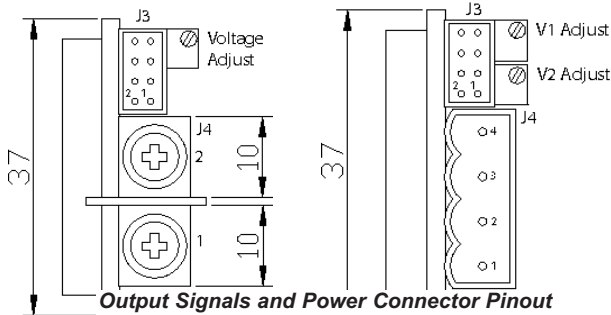

Output Mating Connectors

J3: Locking Molex 51110-0860; Non Locking Molex 51110-0850; Crimp Terminal: Molex p/n 50394.

J4: M4 Screw

J4 Mating Connectors:

Type A: M4 Screw Terminals

Type B: Camden p/n CTB9200/4A

Series Connection

To achieve increased output voltages, simply series outputs using standard series links, paying attention to the requirements to maintain SELV levels if required in your system.

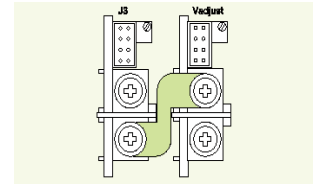

Series Links available. Part Number XS1

Parallel Connection for *powerMods* XgA to XgL

To achieve increased current capacity, simply parallel outputs using the standard parallel links. Excelsys 'wireless' sharing ensures that current hogging is not possible. To parallel connect outputs:

1. Switch on IShare switch to ON for *powerMods* XgG - XgL or add jumper to current share header LK1 for *powerMods* XgA-XgD.
2. Connect Negative Parallel Link.
3. Adjust output voltages of *powerMods* to within 5mV of each other.
4. Connect Positive Parallel Link.

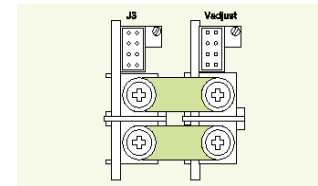

Parallel Links available to order. Part Number XP1

DIP Switch for Current Share & Inhibit/Enable for *powerMods* XgG to XgL



DIP Switch Option for XgG to XgL

powerMods can be configured to be normally ON or normally OFF by appropriate setting of the DIP switch on the *powerMod*. (default mode is normally ON). The *powerMod* will deliver output voltage when mains is applied (and the *powerPac* is enabled). The *powerMod* requires an external 5V signal (between +IN/EN and -IN/EN) to disable the output pins. This may be reversed by setting of the dip switch to the OFF position.

LK1 for Current Share on *powerMods* XgA to XgD

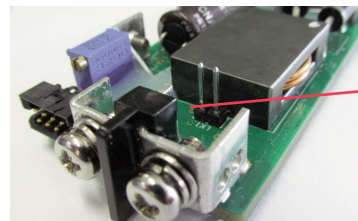

LK1 (Attach jumper here)

Recommended Jumper for LK1: HARWIN M7567-05 (Jumper Socket, Black, 2.54mm, 2-way)

Output Signals and Power Connector Pinout

| Pin | J3 | J3 | J3 | J3 | J4 | J4 |
|--------|--------------|-----------------|----------|--------------|----------|----------|
| Module | (XgA to XgD) | (XgG to XgL) | (XgE) | (XgF) | (Type A) | (Type B) |
| 1 | not used | +Sense | not used | - pg (V2) | -Vout | -V2 |
| 2 | Common | -Sense | not used | +pg (V2) | +Vout | +V2 |
| 3 | not used | Vtrim | not used | Inhibit (V2) | | -V1 |
| 4 | not used | Itrim | Common | Common (V2) | | +V1 |
| 5 | +Inhibit | +Inhibit/Enable | -pg | -pg (V1) | | |
| 6 | -Inhibit | -Inhibit/Enable | +pg | +pg (V1) | | |
| 7 | not used | +pg | Inhibit | Inhibit (V1) | | |
| 8 | not used | -pg | Common | Common (V1) | | |

Section 4.8

powerMod Signals

powerMod Enable/Inhibit

Each *powerMod* may be enabled/inhibited by means of an appropriate signal applied to an opto-isolated input on pins J3 pin 5 (positive) and J3 pin 6 (negative), on *powerMods* XgG to XgL. Inhibit is available by means of an appropriate signal applied to an opto-isolated input on J3 pin7 on XgE, on J3 pin 3 and pin 7 on XgF and pin J3 pin5(positive) and J3 pin 6 (negative) on *powerMods* XgA to XgD. The output voltage of the *powerMod* will be fully inhibited to 0V. Turn-on delay from AC in and Global Enable is typically 2ms but is load dependant.

| | XgG to XgL | XgE, XgF |
|------------------------------|------------|----------|
| Maximum signal input voltage | 12V | 0.8V |
| Minimum signal input voltage | 3V | 0V |
| Minimum current required is | 1.7mA | |

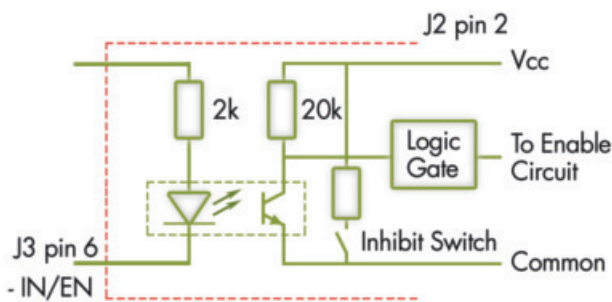

Remote Inhibit/Enable of Output

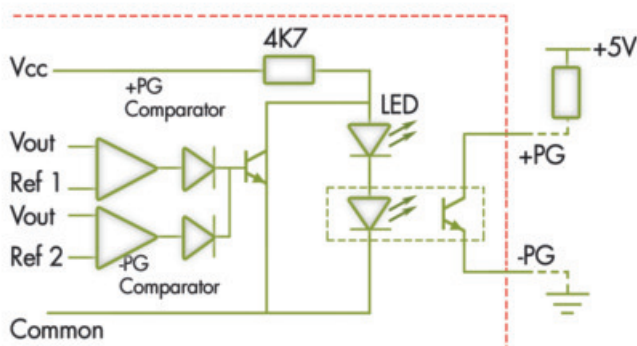

Output powerMods Power Good Signal

powerMod Power Good Signal (XgG - XgL)

Each *powerMod* contains an internal comparator which monitors the output voltage and determines whether this voltage is within normal operation limits. When the output voltage is within normal limits, the Power Good signal is activated.

For XgG-XgL, an opto-isolated signal is generated and available on J3 pin 7 and J3 pin 8. (opto-transistor ON = Good). For XgE, signal is available on J3 Pin 6 and J3 Pin5. For XgF, V1 signal available on J3 Pin 6 and J3 Pin 5. V2 signal is available on J3 Pin 2 and J3 Pin 1.

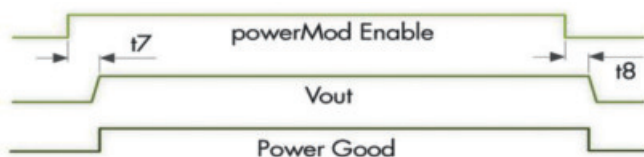

Output powerMod Signals

Maximum collector current is 2mA.

Maximum Collector voltage is 30V.

$t7 < 30ms$

$t8 < 30ms$

powerMod LED Indicator

The LED indicator on each *powerMod* module gives a visual indication of the information contained in the Power Good signal above.

Section 4.9

powerPac Operation

The UltiMod *powerPac* provides the front end input power to the UltiMod *powerMods*. This is available in two package sizes and a number of power ratings. See Section 4.11, Power Ratings for more detail.

Bias Voltage

A SELV isolated bias (always on) voltage of 5V @ 500mA is provided on J2 pin 2 relative to J2 pin 1 (common) and may be used for miscellaneous control functions.

For medical applications, this bias supply voltages has 4000VAC isolation.

Section 4.10

powerPac (Global) Signals

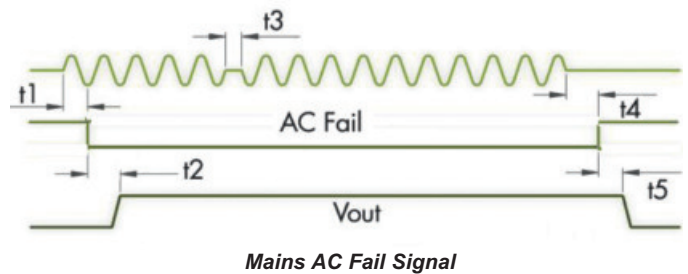

Mains AC Fail Signal

AC Fail

AC Mains Fail signal is implemented by an Opto-isolated signal with a maximum sink current of 4mA. During normal operation the transistor is ON. When the input voltage is lost or goes below 80Vac, the opto-transistor is turned OFF at least 5mS before loss of output regulation (at nominal *powerMod* voltage or below).

$80ms < t1 < 600ms$

$80ms < t2 < 100ms$

$t3 = 10ms$

$t4 > 10ms$

$t5 > 2ms$

Global Inhibit

A global inhibit function may be implemented via simple contact closure as shown. This function inhibits ALL *powerMod* outputs except the auxiliary bias voltage. Global inhibit also shuts down the *powerPac* fans.

Global Enable

A global enable function may be implemented via simple contact closure as shown in the diagram. Ensure that J2 pin 8 and J2 pin 1 are connected prior to contact closure. This function enables ALL *powerMod* outputs and the *powerPac* fans.

Global Enable Using an External Signal

A global enable function may be implemented using a signal from the system using the diagram shown. This function enables ALL *powerMod* outputs.

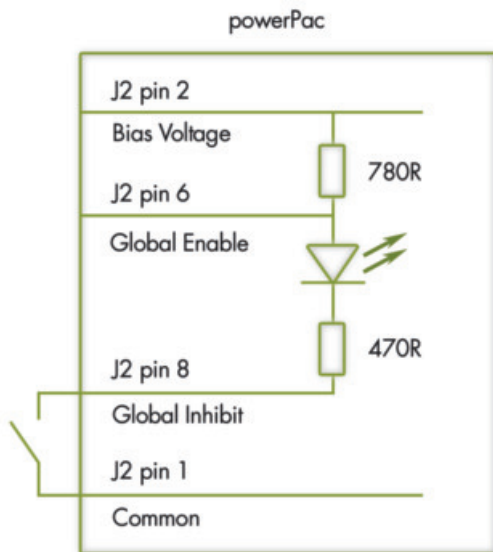

Global Inhibit Using Bias Supply Voltage

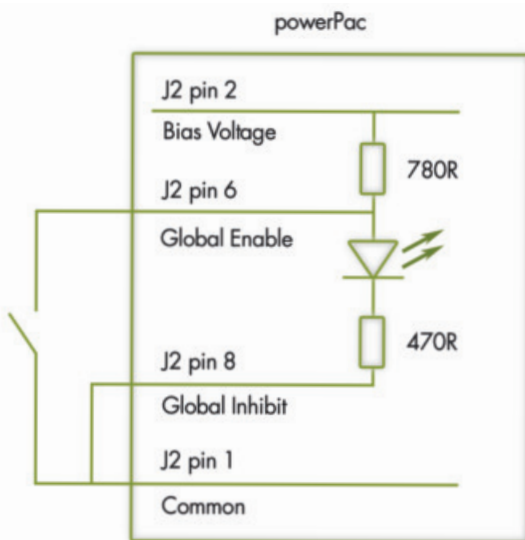

Global Enable Using Bias Supply Voltage

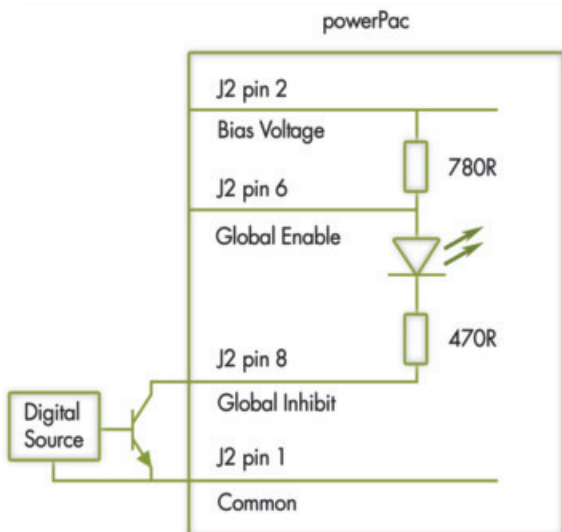

Global Inhibit Using an External Signal

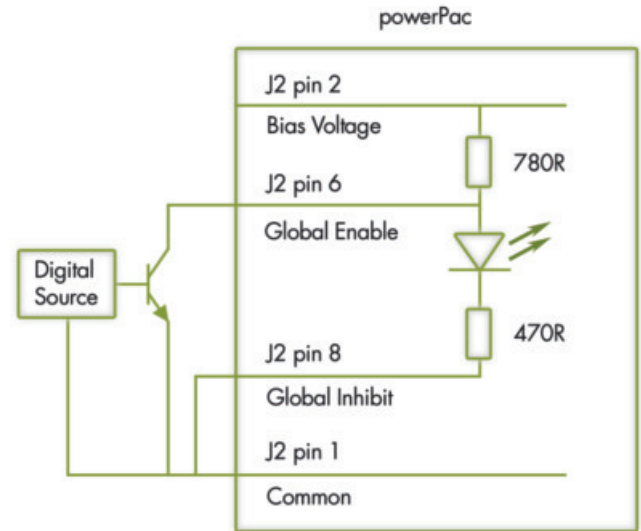

Global Enable Using an External Signal

Temperature Alarm

Open collector signal indicating that excessive temperature has been reached due to fan failure or operation beyond ratings. This signal is activated at least 10ms prior to system shutdown.

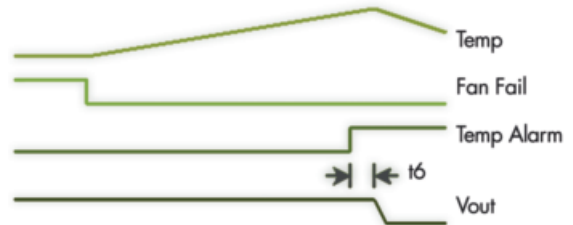

Over-temperature and Fan Fail

Fan Fail

Open collector signal indicating that at least one of the *powerPac* fans has failed. This does not cause power supply shutdown. The power supply will continue to operate until 10ms after the temperature alarm signal is generated.

Ruggedised Option

UltiMod is available with extra ruggedisation as standard for applications that are subject to extremes in shock and vibration. These parts have been tested on 3 axes, for a total of 300hours at 1.67g's rms. All UltiMod power supplies can withstand. Shock >60G, per MIL-STD 810G.

Section 4.11

powerPac Options

Reverse Fan (Option 02)

The UltiMod is available with reverse air flow direction. This is ideal to expel air from the system and works particularly well with the internal fan cooling built into the overall system. Contact factory for details.

Ultra Low Leakage Current (Option 04)

The UltiMod is available with the option of Ultra Low Earth Leakage Current of <150µA. This is ideal for Medical applications using two power supplies or containing additional parts that contribute to the system Earth Leakage Current, ensuring system Earth Leakage current does not exceed levels defined in EN60601-1 and UL60601-1 2nd and 3rd Editions.

Conformal Coating (Option C)

UltiMod is available with conformal coating for harsh environments and MIL-COTs applications. It is IP50 rated against dust and protected against vertical falling drops of water and non condensing moisture, e.g. UX6ABDDL0C00 is a conformal coated 1000W configured UltiMod.

Input Cable Option (Option D)

3 Wire input mains cable. Input cables are 300mm in length and come supplied with fast on connectors. See Section 4.7 for mechanical drawing.

**Section 4.12
Power Ratings**

When specifying an UltiMod power supply in an application it is necessary to ensure that *powerPacs* and *powerMods* are operating within their power output capabilities, taking into account the Temperature Derating and Input Voltage Derating. *powerMods* are designed to provide maximum output power at the nominal output voltages. The maximum permissible output power that may be drawn from any *powerMod* is given in the *powerMod* specification table in Section 4.6.

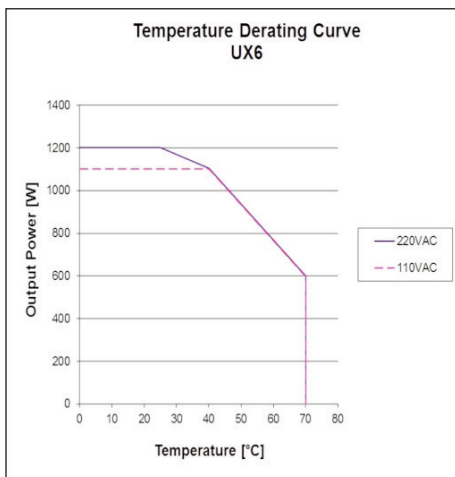
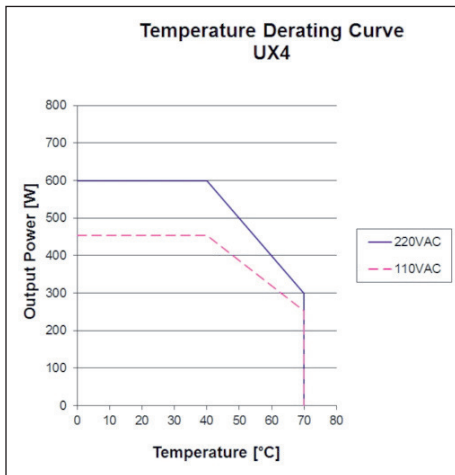

Consult the UltiMod Configurator for further derating information at http://www.excelsys.com/xgen_configurator/configure.html.

**Section 4.13
Reliability**

The 'bath-tub' curve shows how the failure rate of a power supply develops over time. It is made up of three separate stages. Immediately after production, some units fail due to defective components or production errors. To ensure that these early failures do not happen while in the possession of the user, Excelsys carries out a burn-in on each unit, designed to ensure that all these early failures are detected at Excelsys. After this period, the power supplies fail very rarely, and the failure rate during this period is fairly constant. The reciprocal of this failure rate is the MTBF (Mean Time Between Failures).

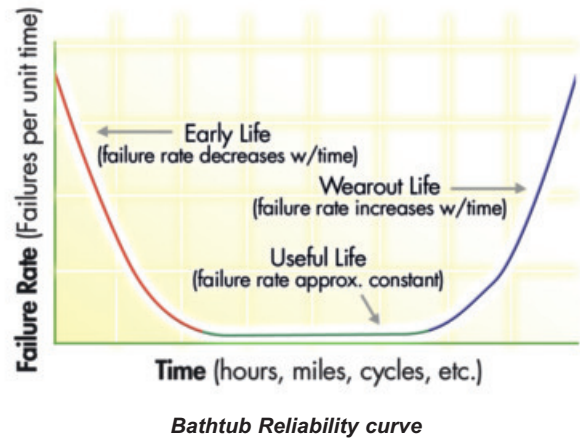

At some time, as the unit approaches its end of life, the first signs of wear appear and failures become more frequent. Generally 'lifetime' is defined as that time where the failure rate increases to five times the statistical rate from the flat portion of the curve.

In summary, the MTBF is a measurement of how many devices fail in a period of time (i.e. a measure of reliability), before signs of wear set in. On the other hand, the lifetime is the time after which the units fail due to wear appearing.

The MTBF may be calculated mathematically as follows:

$MTBF = \text{Total} \times t / \text{Failure}$, where
 Total is the total number of power supplies operated simultaneously.
 Failure is the number of failures.
 t is the observation period.

MTBF may be established in two ways, by actual statistics on the hours of operation of a large population of units, or by calculation from a known standard such as Telecordia SR-332 and MIL-HDBK-217 and its revisions.

Determining MTBF by Calculation

MTBF, when calculated in accordance with Telecordia, MIL-HDBK-217 and other reliability tables involves the summation of the failure rates of each individual component at its operating temperature. The failure rate of each component is determined by multiplying a base failure rate for that component by its operating stress level.

The result is FPMH, the failure rate per million operating hours for that component.

Then FPMH for an assembly is simply the sum of the individual component FPMH.

Total FPMH = FPMH1 + FPMH2 + +FPMHn

$$MTBF \text{ (hours)} = \frac{1,000,000}{FPMH}$$

In this manner, MTBF can be calculated at any temperature. The UltiMod series has the following failure rates at 40°C and full load, based on Telecordia SR-332 standard.

- powerMod* 0.958 failures per million hours
- 4slot *powerPac* 0.92 failures per million hours
- 6slot *powerPac* 0.946 failures per million hours

The figures for the *powerPac* excludes fans.

Example:

What is the MTBF of UX4DD00

UX4 FPMH = 0.92

XgD FPMH = 0.286

Total FPMH = 1.49

MTBF = 670,000 hours at 40°C

MTBF and Temperature

Reliability and MTBF are highly dependent on operating temperature. The figures above are given at 40°C. For each 10°C decrease, the MTBF increases by a factor of approximately 2. Conversely, however, for each 10°C increase, the MTBF reduces by a similar factor. Therefore, when comparing manufacturer's quoted MTBF figures, look at the temperature information provided.

Section 4.14 Safety Approvals

Low Voltage Directive (LVD) 2006/95/EC

The LVD applies to equipment with an AC input voltage of between 50V and 1000V or a DC input voltage between 75V and 1500V. The UltiMod series is CE marked to show compliance with the LVD.

The relevant European standards for the UltiMod are:

- EN60950 (Information technology). The 2nd Edition of this standard is now published and all relevant Excelsys power supplies are certified to the latest edition as well as the 1st Edition.
- EN60601-1 (Medical Devices Directive). The 3rd Edition of this standard is published and all Excelsys medically approved power supplies are certified to this latest edition as well as the 2nd Edition.
- With appropriate packaging, the UltiMod can also meet the requirements of EN61010-1 for industrial scientific measuring equipment and process control.

UX4 and UX6 models are certified to comply with the requirements of IEC950, EN60950, UL60950 (1st and 2nd Editions), and CSA 22.2 no. 234 and IEC1010, when correctly installed in a limited access environment.

The UX4 and UX6 models are certified to comply with the requirements of IEC601-1, EN60601-1, UL60601-1 (2nd and 3rd Editions) and CSA601-1, for non-patient connect applications.

powerMods are capable of providing hazardous energy levels (>240 VA). Equipment manufacturers must provide adequate protection to service personnel.

Environmental Parameters

The UltiMod series is designed for the following parameters:

- Material Group IIIb, Pollution Degree 2
- Installation Category 2
- Class I
- Indoor use (installed, accessible to Service Engineers only).
- Altitude: -155 metres to +2000 metres from sea level.
- Humidity: 5 to 95% non-condensing.
- Operating temperature -20°C to 70°C
- Derate to 70°C. See *powerPac* Derating for details.

Approval Limitations Use in North America

When this product is used on 180 to 253 Volts AC mains with no neutral, connect the two live wires to L (live) and N (neutral) terminals on the input connector.

UltiMod Creepage Distances

- Primary mains circuits to earth: 4mm spacing
- Primary mains circuits to secondary: 8mm spacing

UltiMod Dielectric strength

- Primary mains circuits to chassis: 1500VAC
- Primary mains circuits to secondary: 4000VAC

The primary to secondary test is not possible with modules fitted to the unit, as damage to the EMI capacitors will occur.

Output Isolation

Outputs are each isolated 500V DC to each other and 500 V DC to chassis.

Section 4.15 Electro Magnetic Characteristics

EMC Directive 89/336/EEC

Component Power Supplies such as the UltiMod series are not covered by the EMC directive. It is not possible for any power supply manufacturer to guarantee conformity of the final product to the EMC directive, since performance is critically dependent on the final system configuration. System compliance with the EMC directive is facilitated by UltiMod compliance with several of the requirements as outlined in the following paragraphs. Although the UltiMod product series meet these requirements, the CE mark does not cover this area.

EMISSIONS

Power Factor (Harmonic) Correction

The UltiMod series incorporates active power factor correction and therefore meets the requirements of EN61000-3-2. Power factor: 0.98

EN61000-3-3 Flicker & Voltage Fluctuation Limits

UltiMod power supplies meet the requirements of the limits on voltage fluctuations and flicker in low voltage supply systems.

EN55022 Class B Conducted Emissions

Under appropriate test conditions, the UltiMod series meets the requirements of EN55022 Class B, without the need for external filtering.

IMMUNITY

The UltiMod series has been designed to meet, and tested to, the immunity specifications outlined below:

EN61000-4-2 Electrostatic Discharge Immunity

8kV Air discharge applied to Enclosure

6kV Contact with Enclosure

EN61000-4-3 Radiated Electromagnetic Field
10Volts/metre 80MHz to 2.5GHz applied to Enclosure

EN61000-4-4 Fast Transients-Burst Immunity
+/-2kV

EN61000-4-5 Input Surge Immunity
+/-2kV Common Mode 1.2/50 S (Voltage); 8/20uS (Current)
+/- 1kV Differential Mode 1.2/50 S (Voltage) 8/20 S (Current)

EN61000-4-6 Conducted Immunity
10 V/m 150KHz to 80MHz

EN61000-4-11 Voltage Dips
0% 1s Criteria B
40% 100ms Criteria B
70% 10ms Criteria A

Further details on all tests are available from Excelsys.

Guidelines for Optimum EMC Performance

The UltiMod is designed to comply with European Normative limits (EN) for conducted and radiated emissions and immunity when correctly installed in a system. See performance levels attained above. However, power supply compliance with these limits is not a guarantee of system compliance. System EMC performance can be impacted by a number and combination items. Design consideration such as PCB layout and tracking, cabling arrangements and orientation of the power supply amongst others all directly contribute to the EMC performance of a system.

Cabling arrangements and PCB tracking layouts are the greatest contributing factors to system EMC performance. It is important that PCB tracks and power cables are arranged to minimise current carrying loops that can radiate, and to minimise loops that could have noise currents induced into them. All cables and PCB tracks should be treated as radiation sources and antenna and every effort should be made to minimise their interaction

- a. Keep all cable lengths as short as possible.
- b. Minimise the area of power carrying loops to minimise radiation, by using twisted pairs of power cables with the maximum twist possible.
- c. Run PCB power tracks back to back.
- d. Minimise noise current induced in signal carrying lines, by twisted pairs for sense cables with the maximum twist possible.
- e. Do not combine power and sense cables in the same harness
- f. Ensure good system grounding. System Earth should be a "starpoint". Input earth of the equipment should be directed to the "starpoint" as soon as possible. The power supply earth should be connected directly to the "starpoint". All other earths should go to the 'starpoint'.

Section 4.15

Configuring your UltiMod

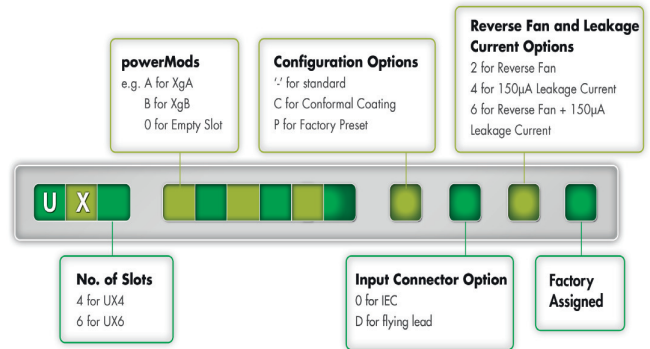

Configuration Example 1: UX4CGD0-D4 contains;
UX4 powerPac: 600W 4-slot chassis, Standard module settings:

- Slot 1: XgC: 36V/5.6A
- Slot 2: XgG: 2.5V/40A
- Slot 3: XgD: 48V/4.2A
- Slot 4: Empty
- Option D: Input cable option; Option 4: 150µA leakage current option.

Configuration Example 2: UX4CGD0PD4B contains;
UX4 powerPac: 600W 4-slot chassis, Factory preset module settings:

- Slot 1: XgC: 32V/5.6A XgC output voltage factory adjusted to 32V
- Slot 2: XgG: 2.5V/40A
- Slot 3: XgD: 46V/4.2A XgD output voltage factory adjusted to 46V
- Slot 4: Empty
- Option D: Input cable option; Option 4: 150µA leakage current option; B: Factory assigned unique identifier.

Configuration Example 3: UX6BBDDA0C02A contains;
UX6 powerPac: 1200W 6-slot chassis, Factory preset module settings:

- Slot 1: XgB: 24V/8.3A (set in parallel with Slot 2)
- Slot 2: XgB: 24V/8.3A (set in parallel with Slot 1)
- Slot 3: XgD: 46V/4.2A XgD output voltage factory adjusted to 46V
- Slot 4: XgD: 48V/4.2A
- Slot 5: XgA: 12V/12.5A
- Slot 6: Empty
- Option C: Conformal Coated; Option 2: Reverse Fan; B: Factory assigned unique identifier.

Configure your UltiMod using our Online Configurator
Our Sales and Applications teams will be delighted to assist you in defining the best power supply for your application. You can also use our online configurator available at http://www.excelsys.com/xgen_configurator/configure.html.

TECHNICAL RESOURCES



CONSULT AN ENGINEER

Our experienced applications engineering team are ready to provide design consultancy support including product recommendations to deliver optimal systems performance, and most importantly reduced time to market. We are committed to providing you with the highest performing, most reliable power solution ensuring the lowest total cost of ownership for you.

To contact one of our team please e-mail support@excelsys.com or telephone:

North America and Canada: +1 972 771 4544

Europe and Asia: +353 21 4354716



ONLINE RESOURCES

Our website www.excelsys.com hosts a wide range of easily accessible resources to support your power supply decision making. This includes:

- **Application Notes:** Supporting system designers in the integration of the Excelsys power supplies into their system.
- **Safety and Environmental Certification:** All our power supplies carry full international safety agency approvals including UL and EN for information technology and medical power supplies. To ease the system safety approvals we have provided our UL and CB certificates and we have also included our declarations of conformity. All Excelsys power supplies are REACH and RoHS compliant. Visit our Safety and Environmental section online where you can download our UL and CB safety certifications, and declarations of conformity to simplify system compliance.

- **EMI Characterisation:** Excelsys power supplies are component power supplies and as such are not subject to the EMC directive for EMI, however in order to ease system integration, Excelsys Technologies has carried out extensive EMI characterization of our products against the relevant standards.
- **HALT (Highly Accelerated Life Testing):** Poor reliability, low MTBF, frequent field returns, high in-warranty costs and customer dissatisfaction are often the result of design and/or process weaknesses, even if a product has successfully passed qualification tests and burn-in. Excelsys Technologies subjects all our products to the HALT (Highly Accelerated Life Testing) process to uncover design and/or process weaknesses. During the HALT process, the product is subjected to progressively higher stress levels brought on by thermal dwells, vibration, rapid temperature transitions and combined environments.
- **White Papers:** Excelsys team of experienced power supply designers have an extensive knowledge of power supplies, technology and the challenges facing system designers. In conjunction with the UltiMod Designers' Manual, and Application Notes, we also prepare White Papers on topics that are relevant to system designers.
- **Designers' Manual:** The UltiMod Designers' Manual has been prepared to assist engineers and technicians in understanding correct design practices necessary to achieve the maximum versatility and performance from any of the UltiMod products. Whatever your application, be it industrial electronics, medical equipment, automation equipment etc., the UltiMod Designers' Manual provides the system designer with easy to implement integration instructions. The Designers' Manual is available can be downloaded from the Excelsys website.
- **Datasheets:** There is an UltiMod for every application. Our data sheets can be downloaded online.

exce

S